

2-Axis Motion Controller

2-Axis board type programmable motion controller

■ Features

- Enable to control 2-axis independent AC servo motor and stepping motor
- PC-ISA Type Card
- Interpolation on circular/linear, bit pattern/continuous/ac • deceleration drive
- Output pulse Max. 4Mpps
- Countable and comparable the real position
- Compatible with Windows 98, NT, 2000, XP
- Apply the library which can be operated in C++

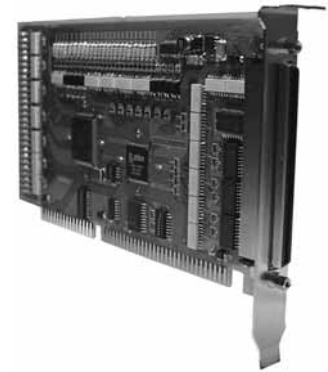

⚠ Please read "Caution for your safety" in operation manual before using.



■ Ordering information

PMC - 2B - ISA

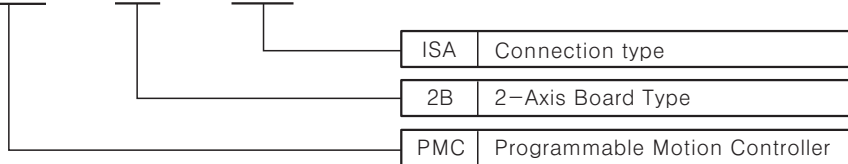

■ Specifications

Model	PMC-2B-ISA
Control axis	2-Axis
ISA bus interface	Data bit width : 16 bit
	I/O possession address : 16 bit
	Interrupt : Available to connect IRQ 3, 4, 5, 6, 7, 10, 11, 12, 14, 15
Shortcut function	2-Axis linear interpolation
	Interpolation function : Axis -8,388,607 ~ +8,388,607
	Interpolation speed : 1 ~ 4 MPPS
	Interpolation position accuracy : Max. ±0.5LSB(Within the whole interpolation range)
	Circular interpolation
Interpolation range : Axis -8,388,607 ~ +8,388,607	
Interpolation speed : 1 ~ 4 MPPS	
Interpolation position accuracy : Max. ±1 LSB(In interpolation range)	
2-Axis bit pattern interpolation	Interpolation speed : 1~4MPPS(Dependent only on CPU data setup)
Etc.	Constant linear speed, Continual interpolation, Transmit interpolation STEP(Command, External signal)
Driver pulse output (X, Y common specifications)	Output circuit : Differential operating Line driver output
	Output speed range : 1PPS~4MPPS
	Output speed accuracy : Max ±0.1%(For setting value)
	Speed rate : 1 ~ 500
	S-curve ac.acceleration ascend rate : 954 ~ 62.5×10 ³ PPS/SEC (At rate=1) (Rate of increase) 477×10 ³ ~ 31.25×10 ⁶ PPS/SEC ² (At rate=500)
	Ac.acceleration rate : 125 ~ 1×10 ⁶ PPS/SEC ² (At rate=1) 62.5×10 ³ ~ 500×10 ⁶ PPS/SEC ² (At rate=500)
	Super high speed : 1 ~ 8,000PPS (At rate=1) 500 ~ 4×10 ⁶ PPS/SEC ² (At rate=500)
	Drive speed : 1 ~ 8,000PPS (At rate=1) 500 ~ 4×10 ⁶ PPS/SEC ² (At rate=500)
	Output pulse : 0 ~ 268,435,455(Fixed quantity drive)
	Speed curve:Constant speed/Linear ac.acceleration speed /Parabola S-curve ac.acceleration speed drive
	Decelerate mode of fixed drive / Manual deceleration
	Output pulse on Driving, Available to change drive speed
	Selectable dependent 2pulse / 1pulse direction type
	Selectable logic level

PMC-2B-ISA

Specifications

Encoder input pulse	Input circuit:High speed photo-coupler input, Able to connect with differential operating line drive 2phase pulse(Up/Down pulse input)
Direction counter	Logic position counter(For output pulse) count range : -2,147,483,648 ~ +2,147,483,647 Real position counter(For input pulse) count range : -2,147,483,648 ~ +2,147,483,647
Compare register	COMP+ register position compare range : -2,147,483,648 ~ +2,147,483,647
	COMP- register position compare range : -2,147,483,648 ~ +2,147,483,647
	Status output and signal output the magnitude with position counter Available operating as a software limit
Interrupt function (Except for interpolation)	<ul style="list-style-type: none"> • 1drive pulse output • On changing position counter \geq COMP+ • On changing position counter $<$ COMP- • On changing position counter $<$ COMP- • Starting fixed speed on ac.decelaration drive • On changing position counter \geq COMP+ • On changing position counter $<$ COMP+ • Completing fixed speed on ac.decelaration drive • On drive ending
Drive shortcut by external signal	Able to drive fixed quantity • continual speed of +/- direction by EXPP, EXPM signal Input circuit : Photo-coupler + Integral filter circuit, Able to connect mechanical contact
E decelerate stop / Immediate stop signal	IN0 ~ 2square axis 3points Input circuit : Photo-coupler + Integral filter circuit
Input signal for servo motor	ALARM(alarm), INPOS(Complete position set) Input circuit : Photo-coupler + CR integral filter circuit
Output signal for common	OUT0 ~ 5square axis 6points(Multiple 4 combines MULT CHIP shortcut signal and terminal)
	OUT0 ~ 7square axis 8points(Dual purpose of driver status output signal and terminal) Output circuit : Open collector output
Signal output on drive	<ul style="list-style-type: none"> • DRIVE (Driver pulse output) • ASND (Ascend speed) CNST (Constant speed) DSND (Descend speed) • CMPP (Position \geq COMP+), CMPM (Position $<$ COMP-) • ACASND (Accelerated ascend speed), ACDSND (Accelerated descend)
Overrun limit signal input	Direction +, - each one Input circuit: Photo-coupler+ CR integral filter circuit
Emergency stop signal input	ENGN 1point in all axis, make drive pulse of all axis immediately stop Input circuit : Photo-coupler + CR integral filter circuit
Etc.	Operating temp. range : 0 ~ 45°C (Non-freezing and non-dew condition)
	Power supply : 5DCV \pm 5% (Max. Current consumption 700mA)

System

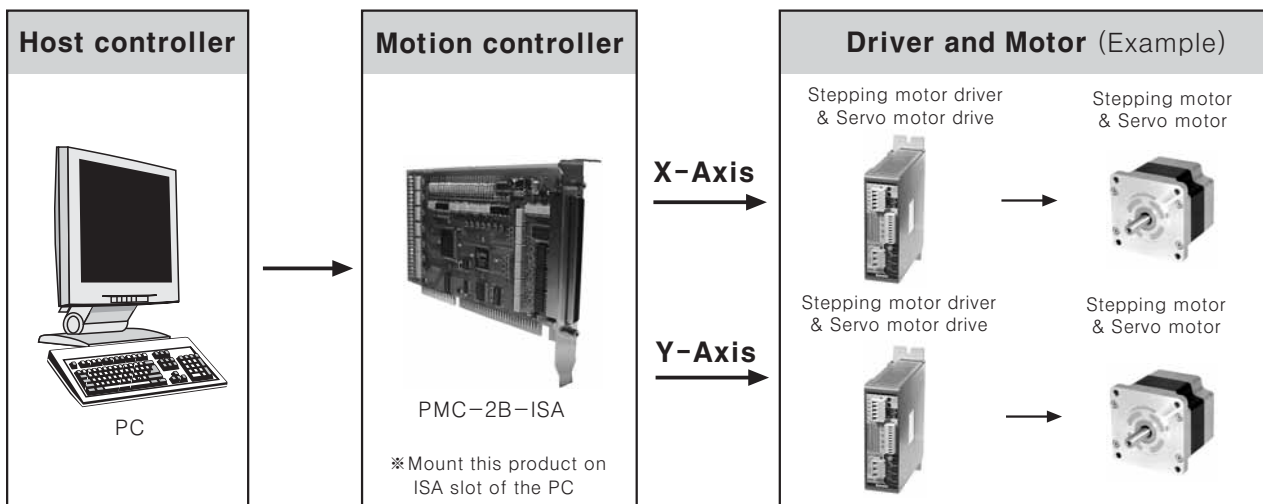

2-Axis Motion Controller

Dimensions

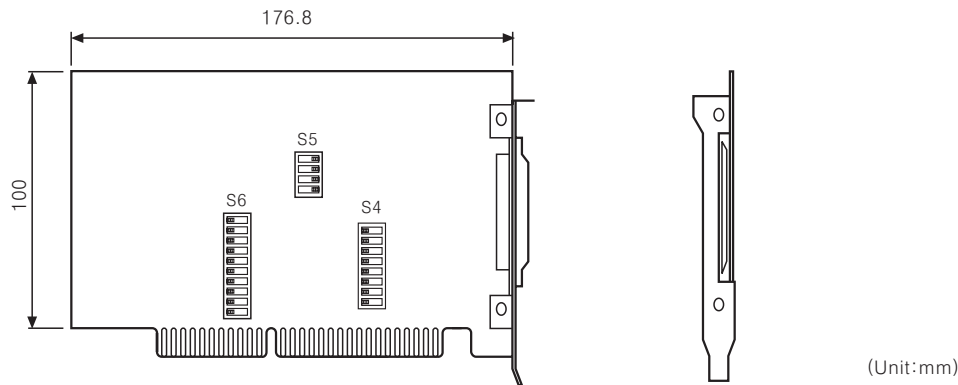

Connections

Connection of drive pulse output signal (nPPP/M, nPMP/M)

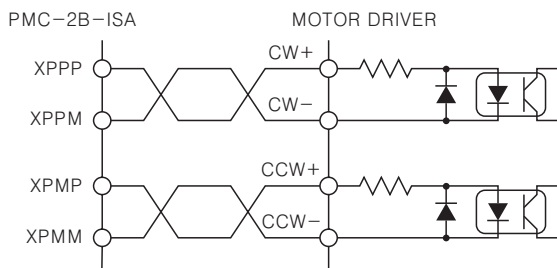

< Photocoupler input circuit >

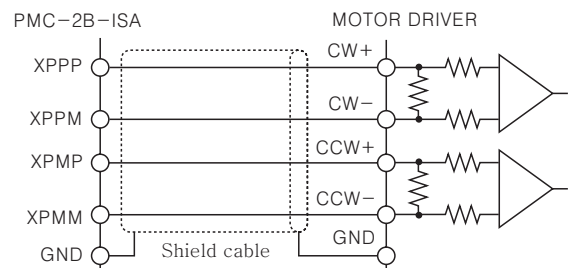

< Line receiver input circuit >

Connection of limit input signal on photo micro sensor

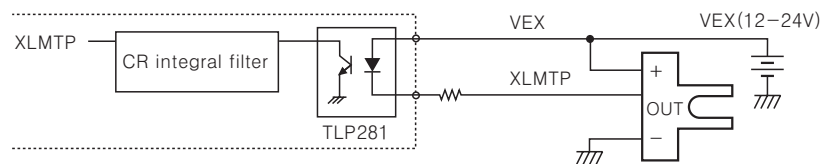

Connection of 5-phase microstepping driver

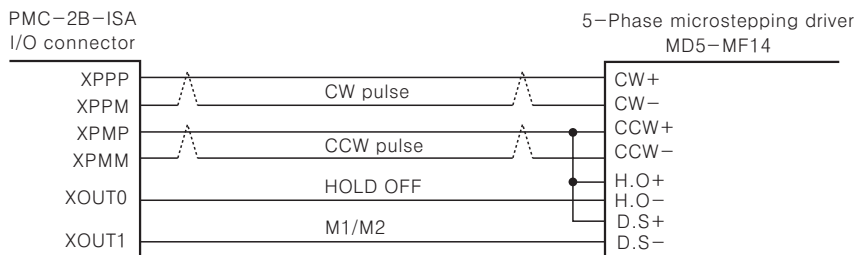

Connection of encoder input signal (nECAP, nECAN, nECBP, nECBN)

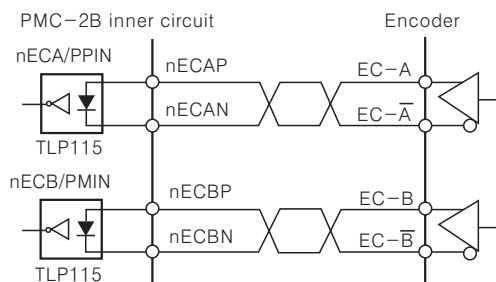

< LINE DRIVER connection >

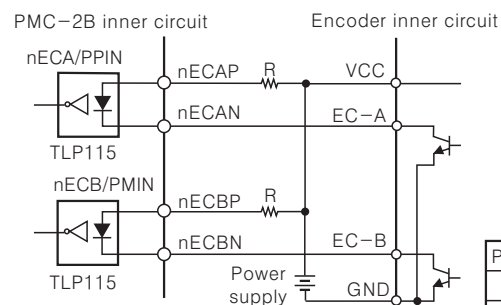

< NPN OPEN COLLECTOR output connection >

Power supply(V)	R(Ω)
5	0
12	820 1/4w
24	2K 1w

PMC-2B-ISA

■ Specifications(Input/Output)

Pin	Signal	Description	Pin	Signal	Description
1	VEX	External power (12-24VDC)	51	VEX	External power (12-24VDC)
2	GND	Ground of VEX	52	GND	Ground of VEX
3	EMGN	Emergency stop	53	EMGN	Emergency stop
4	XLMTTP	Axis X +limit	54	YLMTTP	Axis Y +limit
5	XLMTM	Axis X -limit	55	YLMTM	Axis Y -limit
6	XSTOPO	Axis X deceleration stop/Immediate stop(near home)	56	YSTOPO	Axis Y deceleration stop/Immediate stop(near home)
7	XSTOP1	Axis X deceleration stop/Immediate stop(home)	57	YSTOP1	Axis Y deceleration stop/Immediate stop(home)
8	XSTOP2	Axis X deceleration stop/Immediate stop(near home)	58	YSTOP2	Axis Y deceleration stop/Immediate stop(near home)
9	XINPOS	Axis X servo inposition	59	YINPOS	Axis Y complete servo inposition
10	XALARM	Axis X servo alarm	60	YALARM	Axis Y servo alarm
11	XECAP	Axis X Encoder phase A +	61	YECAP	Axis Y Encoder phase A +
12	XECAN	Axis X Encoder phase A -	62	YECAN	Axis X Encoder phase A -
13	XECBP	Axis X Encoder phase B +	63	YECBP	Axis X Encoder phase B +
14	XECBN	Axis X Encoder phase B -	64	YECBN	Axis X Encoder phase B -
15	XPPP	Axis X +direction drive pulse	65	YPPP	Axis Y +direction drive pulse
16	XPPM	Axis X +direction drive pulse	66	YPPM	Axis Y +direction drive pulse
17	XPMP	Axis X -direction drive pulse	67	YPMP	Axis X -direction drive pulse
18	XPMM	Axis X -direction drive pulse	68	YPMM	Axis X -direction drive pulse
19	XIN0	Axis X common input 0	69	YIN0	Axis Y common input 0
20	XIN1	Axis X common input 1	70	YIN1	Axis Y common input 1
21	XIN2	Axis X common input 2	71	YIN2	Axis Y common input 2
22	XIN3	Axis X common input 3	72	YIN3	Axis Y common input 3
23	XIN4	Axis X common input 4	73	YIN4	Axis Y common input 4
24	XIN5	Axis X common input 5	74	YIN5	Axis Y common input 5
25	XEXPP	Axis X +direction drive controlling	75	YEXPP	Axis Y +direction drive controlling
26	XEXPM	Axis X -direction drive controlling	76	YEXPM	Axis X -direction drive controlling
27	UIN0	User common input 0	77	UIN8	User common input 8
28	UIN1	User common input 1	78	UIN9	User common input 9
29	UIN2	User common input 2	79	UIN10	User common input 10
30	UIN3	User common input 3	80	UIN11	User common input 11
31	UIN4	User common input 4	81	UIN12	User common input 12
32	UIN5	User common input 5	82	UIN13	User common input 13
33	UIN6	User common input 6	83	UIN14	User common input 14
34	UIN7	User common input 7	84	UIN15	User common input 15
35	XOUT0	Axis X common output 0	85	YOUT0	Axis Y common output 0
36	XOUT1	Axis X common output 1	86	YOUT1	Axis Y common output 1
37	XOUT2	Axis X common output 2	87	YOUT2	Axis Y common output 2
38	XOUT3	Axis X common output 3	88	YOUT3	Axis Y common output 3
39	XOUT4	Axis X common output 4	89	YOUT4	Axis Y common output 4
40	XOUT5	Axis X common output 5	90	YOUT5	Axis Y common output 5
41	XOUT6	Axis X common output 6	91	YOUT6	Axis Y common output 6
42	XOUT7	Axis X common output 7	92	YOUT7	Axis Y common output 7
43	UOUT0	User common output 0	93	UOUT8	User common output 8
44	UOUT1	User common output 1	94	UOUT9	User common output 9
45	UOUT2	User common output 2	95	UOUT10	User common output 10
46	UOUT3	User common output 3	96	UOUT11	User common output 11
47	UOUT4	User common output 4	97	UOUT12	User common output 12
48	UOUT5	User common output 5	98	UOUT13	User common output 13
49	UOUT6	User common output 6	99	UOUT14	User common output 14
50	UOUT7	User common output 7	100	UOUT15	User common output 15

■ Proper usage

◎ Using this product

This product is wrapped with the antistatic paper. Using this product, please remove the static in body and clothes to grip the both sections of board or metallic installation part. Terminal of connector or equipped component should not be touched, or, the built-in CMOS-IC can be broken in dry weather of winter.

◎ Installation on PC

After setting I/O port address as slide dip switch S4, S5 and insert edge connector to ISA bus connector of PC fastening metallic part with screw.

It should be installed after off the power of PC.

- ① Install the product with counterplan against power failure.
 - It may cause a human injury or damage of property.
- ② Metallic substance should not be closed on a surface of the product.
 - It may cause a fire or malfunction.
- ③ Do not change I/O address setting switch during the power is ON.
 - It may cause a malfunction.
- ④ Do not change interrupt setting switch during the power is ON.
 - It may cause a malfunction.

◎ Connection of Input/Output Signal

When connecting external power or input/output signals, reverse the polarity or give overvoltage or overcurrent, it may cause a breakdown of the circuit components and reducing the reliance.

Please check wiring before connection.

- ① Wiring must be based on the connection diagram.
 - It may cause a fire, electric shock or breakdown of product.
- ② Install safety device on the product to protect the whole system under the problem of external power, controller.
 - It may give an electric shock or damage to product.
- ③ Set the limit switch by all means.
 - It may cause human injury or damage to product.
- ④ Set the EMERGENCY STOP switch by all means.
 - It may cause human injury or damage to product.
- ⑤ Do not set or connect the product when power is ON.
 - It may give an electric shock or damage to product.
- ⑥ Check wires are not to be short-circuited each other when installing and connection.
 - It may give an electric shock or damage to product.
- ⑦ Non-using terminal have not to be connected with other lines and not to be shorted with another terminal.
 - It may give an electric shock or damage to product.

◎ Using I/O cable

Use the I/O cable as short as possible to avoid electromagnetic noise, even I/O cable is 1.2m, the signal of 11~18 and 61~68 is high speed of I/O signal wire(Encoder input signal and pulse output signal).

(It is allowed to lengthen as max.2m.)

- ① I/O cable must be used without noise so please separate the wires from the power cable, operating power cable, load cable.
 - It may cause a malfunction.
- ② Do not change the pin arrangement of I/O cable arbitrarily.