

Autonics Motor Driver(5-Phase microstepping driver) MD5-HF14

M A N U A L



Thank you very much for selecting Autonics products.
For your safety, please read the following before using.

Caution for your safety

- Please keep these instructions and review them before using this unit.
 - Please observe the cautions that follow;
 - Warning** Serious injury may result if instructions are not followed.
 - Caution** Product may be damaged, or injury may result if instructions are not followed.
- The following is an explanation of the symbols used in the operation manual.
- caution: Injury or danger may occur under special conditions.

Warning

- In case of using this unit with machinery(Nuclear power control, medical equipment, vehicle, train, airplane, combustion apparatus, entertainment or safety device etc), it is required to install fail-safe device, or contact us for information on type required.
It may cause serious human injury or a fire, property.
- Installation, connection, operation, control, maintenance should be carried out by person who has been qualified.
It may cause a fire, human injury or give an electric shock.
- It should be installed and earth independently and grounding wire should be over than AWG No.18(0.75mm²).
It may give an electric shock.
- Please install this unit after consider countplan against power failure.
It may cause human injury or damage to product by releasing holding torque of motor.
- Do not use this unit outdoors or place where there are explosiveness, flammable, corrosive gas, water and frequent vibration etc.
It may cause a fire or give an electric shock.
- Do not touch this unit or connection terminal of condenser within 30sec after turn off the power.
It may give an electric shock by residual voltage.
- Do not put finger or any object in to this product.
It may cause a fire or give an electric shock.
- Do not disassemble or modify this unit. Please contact us if it required.
It may cause a fire, give an electric shock or damage to product.
- Please adjust the volume switch with insulated screw driver.
It may give an electric shock.
- It should be insulated not to expose the conductor, because connecting party has a dangerous voltage when join to connector.

Caution

- Do not move, install or maintain during it is operating.
It may give an electric shock.
 - Power input voltage must be used within rating specification and power line should be over than AWG NO. 18(0.75mm²).
It may cause a fire or give an electric shock.
 - Please check the connection before power.
It may cause a fire or give an electric shock.
 - When you connect to power, please install current breaker.
It may cause a fire.
 - Please turn off when power failure occurred.
It may cause human injury or damage to product due to sudden movement by recovering from power failure.
 - Do not touch during the operation or after a while of operation.
It may cause a burn due to high temperature in surface.
 - The emergency stop should be enabled during the operation.
It may cause human injury or damage to product.
 - Please apply power after checking control input signal.
It may cause human injury or damage to product by sudden movement.
 - Do not turn on the HOLD OFF signal input while it is maintaining vertical position.
It may cause human injury or damage to product by releasing holding torque of motor.
 - Please install a safety device when need to remain the vertical position after turn off the power.
It may cause human injury or damage to product by releasing holding torque of motor.
 - Please check if HOLD OFF signal input is ON when need to set the output manually.
It may cause human injury by sudden movement.
 - Please stop this unit when mechanical problem is occurred.
It may cause a fire or human injury.
 - Do not touch the terminal when during the insulation dielectric strength test or insulation resistance measurement.
It may give an electric shock.
 - Please observe rating specification.
It may cause a fire, give an electric shock or damage to product.
 - In cleaning the unit, do not use water or an oil-based detergent.
It may cause a fire or give an electric shock.
 - Please separate as industrial waste when disuse this unit.
 - Use the specified 5-phase stepping motor in motor output terminal.
It may cause a fire or damage to product.
- The above specifications are changeable at anytime without notice.

Specification

MD5-HF14		
Model	MD5-HF14	
Power supply	100-220VAC 50/60Hz	
Allowable voltage range	±10% of rated voltage	
Power consumption (1)	3A(Max.)	
RUN current (2)	0.4~1.4A/Phase	
Drive method	Bipolar constant current pentagon drive	
Resolution	1, 2, 4, 5, 8, 10, 16, 20, 25, 40, 50, 80, 100, 125, 200, 250 division	
Input pulse spec.	Pulse width	Min. 0.25μs (Duty max. 50%)
	Pulse interval	
	Rising/falling time	Max. 1μs
	Pulse input voltage	[H] 4-8VDC, [L] 0-0.5VDC
Max. input pulse frequency (3)		Max. 500kpps
Ambient temperature	0 ~ 50°C	
Ambient humidity	35 ~ 85%RH	
Unit weight	Approx. 660g	

- (1) Ambient temperature is 25°C and ambient humidity is 55%RH.
- (2) The max. value of RUN current is based on RMS value in accordance with frequency of running motor, peak power can be changed by load fluctuation.
- (3) It can be changed by pull-out frequency and max. slewing frequency range.

Dimensions

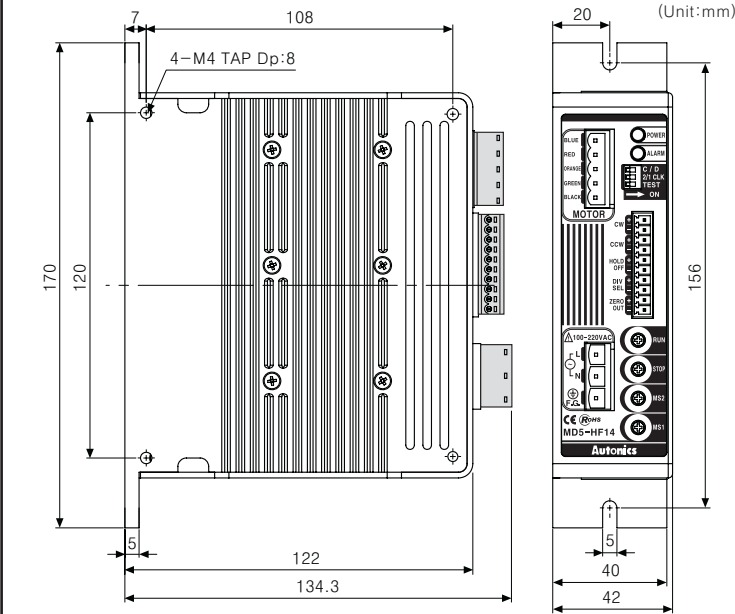

Time charts

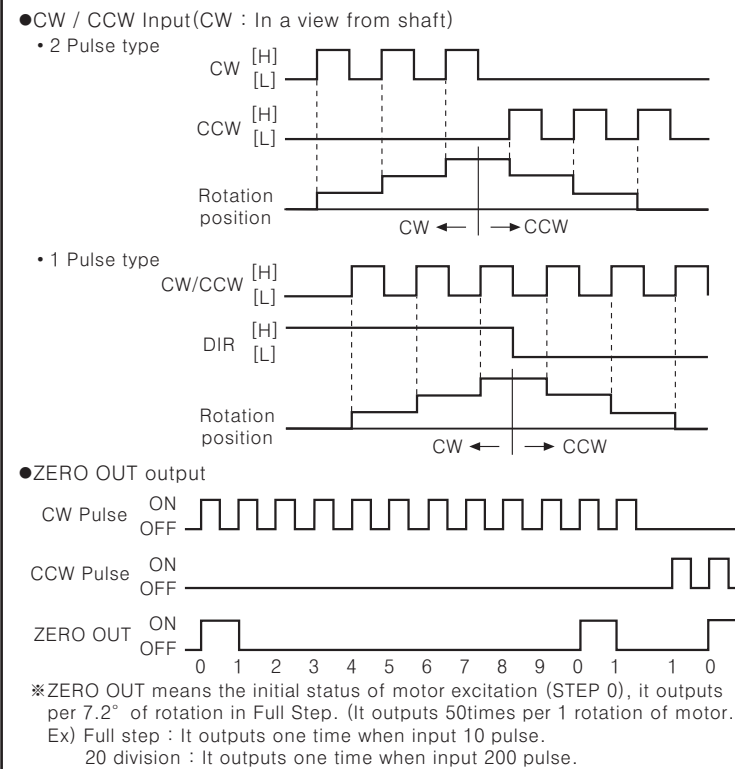

Input · Output diagram

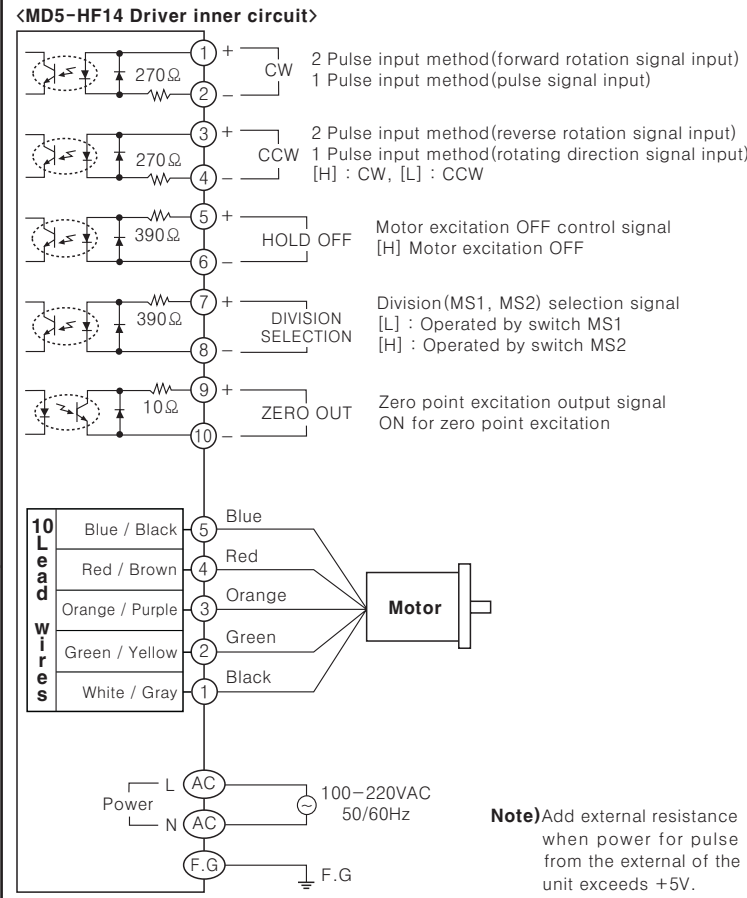

Function

Selectable function switch

No	Name	Function	Switch position	
			ON	OFF
1	TEST	Self diagnosis function	250pps rotation	—
2	2/1 CLK	Pulse input method	1 Pulse input	2 Pulse input
3	C/D	Auto Current Down	—	Use

- TEST**
 ※ It rotates at a speed of 250pps in Full Step and it is changed depending on resolution.
 ※ It rotates to CCW in 1 Pulse input method and CW in 2 Pulse input method.
- 2/1 CLK**
 ※ Pulse input method selection
 ※ 1 Pulse method : Input pulse signal input in CW and rotating direction signal in CCW. It rotates to CCW when [L] and CW for [H].
 ※ Motor is rotated to CW when input pulse in CW and to CCW when input pulse in CCW.
- CURRENT DOWN**
 ※ It reduces RUN current when motor is at standstill to lower the heat generation automatically.
 ※ Current is reduced from approx.500[ms] after the last pulse input.

Setting RUN current

Switch No	0	1	2	3	4	5	6	7	8	9	A	B	C	D	E	F
Current (A/Phase)	0.4	0.5	0.57	0.63	0.71	0.77	0.84	0.9	0.96	1.02	1.09	1.15	1.22	1.27	1.33	1.4

- ※ RUN current is phase current for 5 phase stepping motor.
- ※ There can be an error in RUN current setting value by driving frequency.
- ※ RUN current should be used within the rated current of motor, or it may cause overheating, step-out and loss of torque.

Setting STOP current

Switch No	0	1	2	3	4	5	6	7	8	9	A	B	C	D	E	F
%	27	31	36	40	45	50	54	58	62	66	70	74	78	82	86	90

- ※ STOP current is phase current provided to 5-phase of stepping motor to be stopped.
- ※ The switch setting value of STOP current is a percentage of RUN current switch setting current value.
- ※ There can be an error in STOP current by coil impedance of motor.
- ※ It is operated when HOLD OFF signal is [L] and auto Current down function is not available when it is [H], because current provided to each phase is cut off.

Zero point excitation output signal (ZERO OUT)

It indicates the initial step of excitation status of stepping motor and rotation position of motor axis from previously set zero.

HOLD OFF function

- ※ HOLD OFF is [H], the excitation is released.
- ※ HOLD OFF is [L], the excitation is in a normal status.
- ※ It rotates motor axis by external force or is used for manual positioning.
- ※ Input H/L means ON/OFF of photocoupler in a circuit.

Setting micro step(Micro-step:Resolution)

S/W No	0	1	2	3	4	5	6	7	8	9	A	B	C	D	E	F
Resolution	1	2	4	5	8	10	16	20	25	40	50	80	100	125	200	250

Setting resolution(Same for MS1, MS2)

- ※ It drives a motor dividing basic step angle(0.72°) by setting value of 5-phase stepping motor.
 Rotation angle of 5-phase stepping motor = $\frac{\text{Basic step angle}(0.72^\circ)}{\text{Resolution}}$
- ※ When resolution is changed during the operation of motor, it may cause a step-out of motor.

Selectable resolution(Selectable Step angle)

- ※ Change into the resolution in MS1/MS2 by DIVISION SELECTION input.
- ※ Motor is rotated by resolution in MS1 when DIVISION SELECTION signal is [L] and MS2 for [H].
- ※ Change the resolution after motor is stopped or, it may cause a step-out of motor.
- ※ Input H/L means ON/OFF of photocoupler in a circuit.

Alarm function

- ※ Overheat : When base temperature of driver is over 80°C, alarm LED(Red) is lighted and motor will be stop holding the excitation. Reset the power after remove the existing factors of overheat that can be occurred to release the Alarm.
- ※ Over Current : When overcurrent is applied from breakdown or error to the motor, alarm LED (Red) is flashed. Cut the power motor to recover from the abnormal status after HOLD OFF status.

Failure diagnosis and measurement

- If motor does not rotate
 - Check the connection status of controller and driver and pulse input specification. (Voltage, width)
 - Check the input pulse method and connected method is same.
 - Check pulse and direction signal is connected correctly for 1 pulse input method.
- If motor rotates as a reverse direction.
 - Check input pulse connection of CW and CCW is correct for 2 pulse input method.
 - When the input is [H] with CCW, it is forward rotation and it is reverse rotation for [L].
- If motor does not work properly.
 - Check the connection of driver and motor.
 - Check the pulse input specification of driver. (Voltage, width)
 - Check output current for current adjuster and current for motor operation as correct.
 - After turning off the power, wait at least 15 seconds before turning the power back on.

Caution for using

- Caution for signal input
 - Do not input CW, CCW signal at the same time in 2 Pulse input type. It may not work properly if another direction signal is supplied when one of them is ON.
 - In case, the signal input supply is higher than rated supply expressed on the specification, please connect the additional resistance to external part.
 - Caution for setting the RUN and STOP current
 - RUN current must be set under a rated current of the motor because motor emits heat too much when RUN current is set over a rated current of the motor.
 - STOP current is worked by Auto CURRENT DOWN function when the motor HOLD OFF signal is [L]. In case, the motor HOLD OFF signal is [H], or Auto CURRENT DOWN function is not set, STOP current setting value is not apply to the motor.
 - Caution for wiring
 - Use Twist pair(Over 0.2mm²) for the signal wire should be shorter than 2m.
 - Please use an electric wire is thicker than the motor lead when product the motor wire connection.
 - Please leave a space over 10cm between a signal wire connection and power wire.
 - Caution for installation
 - Please mount a heating panel on metal surface closely.
 - Please mount this product at well-ventilated place in order to increase the heating efficiency of heating panel.
 - Caution for using function switches
 - Check the position of self-diagnosis switch before turn on the power.
 It may be dangerous if turn on the power in [ON] status, due to motor is worked instantly or cause a malfunction.
 - When the selection switch of input signal method is changed to 2 Pulse input method during the operation with 1 Pulse input method, it may be danger as the revolution way of the motor is changed conversely.
 Please do not change the input signal method during the operation.
 - Installation environment
 - It shall be used indoor
 - Pollution Degree 2
 - Altitude Max. 2000m
 - Installation Category II
- It may cause malfunction if above instructions are not followed.

Major products

- PROXIMITY SENSOR ■ PHOTOELECTRIC SENSOR ■ AREA SENSOR
- FIBER OPTIC SENSOR ■ DOOR/DOOR SIDE SENSOR ■ PRESSURE SENSOR
- ROTARY ENCODER ■ SENSOR CONTROLLER
- SWITCHING POWER SUPPLY
- TEMPERATURE CONTROLLER
- TEMPERATURE/HUMIDITY TRANSDUCER
- POWER CONTROLLER ■ RECORDER
- TACHOMETER/PULSE(RATE) METER
- PANEL METER ■ INDICATOR
- SIGNAL CONVERTER ■ COUNTER
- TIMER ■ DISPLAY UNIT
- GRAPHIC PANEL
- STEPPING MOTOR & DRIVER
- MOTION CONTROLLER

Autonics Corporation
<http://www.autonics.com>

Satisfiable Partner For Factory Automation

HEAD QUARTERS :
 41-5, Tongdang-dong, Yangsan-si, Gyeongnam, 626-847, Korea

OVERSEAS SALES :
 (Sing.) 402 3rd Fl., Bushan Techno Park, 193, Yakhid-dong, Woomi-gu, Bucheon-si, Gyeonggi-do, 420-734, Korea
 TEL: 82-32-610-2730 / FAX: 82-32-329-0728
 E-mail: sales@autonics.com

The proposal of a product improvement and development : Product@autonics.com