

# Incremental Manual Handle Type

## Incremental manual handle type Rotary encoder

### ■ Features

- Suitable for manual pulse input type such as numerically controlled or Milling machinery
- Terminal connection type
- Power supply : 5VDC ±5%, 12–24VDC ±5%

### ■ Application

- Industrial tooling machinery

**⚠ Please read "Caution for your safety" in operation manual before using.**



### ■ Ordering information

ENH	–	100	–	1	–	1	–	24
Series		Pulse/1Revolution		Clickstopper position		Control output		Power supply
Handle type		25 100		1 : Normal "H" 2 : Normal "L"		T : Totem pole output V : Voltage output L : Line driver output(※)		5 : 5VDC ±5% 24 : 12–24VDC ±5%

※The power of Line driver is only for 5VDC

### ■ Specifications

Item		Incremental manual handle type of rotary encoder	
Resolution(P/R)		<b>(Note1)</b> 25, 100	
Output phase		A, B phase (Line driver output A, $\bar{A}$ , B, $\bar{B}$ phase)	
Phase difference of output		Phase difference between A and B : $\frac{T}{4} \pm \frac{T}{8}$ (T=1cycle of A phase)	
Control output	Totem pole output	<ul style="list-style-type: none"> <li>• Low <math>\Rightarrow</math> Load current:Max. 30mA, Residual voltage : Max. 0.4VDC</li> <li>• High <math>\Rightarrow</math> Load current:Max. 10mA, Output voltage (Power supply 5VDC):Min. (Power supply–2.0)VDC, Output voltage (Power supply 12–24VDC):Min. (Power supply–3.0)VDC</li> </ul>	
	Voltage output	Load current : Max. 10mA, Residual voltage : Max. 0.4VDC	
	Line driver output	<ul style="list-style-type: none"> <li>• Low <math>\Rightarrow</math> Load current : Max. 20mA, Residual : Max. 0.5V</li> <li>• High <math>\Rightarrow</math> Load current : Max. –20mA, Output voltage : Min. 2.5V</li> </ul>	
Response time (Rise/Fall)	Totem pole output	Max. 1 $\mu$ s	
	Voltage output	Max. 1 $\mu$ s	
	Line driver output	Max. 0.2 $\mu$ s	
Power supply	<ul style="list-style-type: none"> <li>• 5VDC ±5% (Ripple P–P : Max. 5%)</li> <li>• 12–24VDC ±5% (Ripple P–P : Max. 5%)</li> </ul>		
Current consumption	Max. 40mA (disconnection of the load), Line driver output:Max. 50mA (disconnection of the load)		
Max. Response frequency	10kHz		
Insulation resistance	Min. 100M $\Omega$ (at 500VDC mega between all terminals and case)		
Dielectric strength	750VAC 50/60Hz for 1 minute (Between all terminals and case)		
Connection	Terminal block type		
Mechanical specification	Starting torque	Max. 1kgf • cm (0.098N • m)	
	Shaft loading	Radial : 2kgf, Thrust : 1kgf	
	Max. allowable revolution	<b>(Note2)</b> Max. 200rpm (Normal), 600rpm (Peak)	
Vibration	1.5mm amplitude at frequency of 10 ~ 55Hz in each of X, Y, Z directions for 2 hours		
Shock	Max. 50G		
Ambient temperature	–10 ~ 70°C (at non-freezing status), Storage:–25 ~ 85°C		
Ambient humidity	35~85%RH, Storage: 35~90%RH		
Unit weight	Approx. 300g		

※ **(Note1)** Not indicated type is customizable.

※ **(Note2)** Max. allowable revolution  $\geq$  Max. response revolution **[Max. response revolution (rpm) =  $\frac{\text{Max. response frequency}}{\text{Resolution}} \times 60 \text{ sec}$ ]**

(A) Counter

(B) Timer

(C) Temp. controller

(D) Power controller

(E) Panel meter

(F) Tacho/Speed/Pulse meter

(G) Display unit

(H) Sensor controller

(I) Switching power supply

(J) Proximity sensor

(K) Photo electric sensor

(L) Pressure sensor

(M) Rotary encoder

(N) Stepping motor & Driver & Controller

(O) Graphic panel

(P) Production stoppage models & replacement

# ENH Series

## Control output diagram

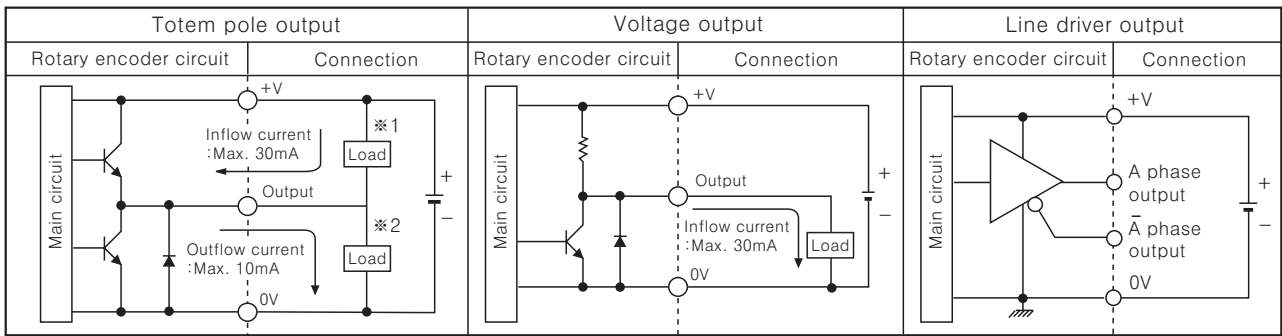

- The output circuit of A, B phase (Line driver output is A,  $\bar{A}$ , B,  $\bar{B}$  phase) are same.
- Totem pole output can be used for NPN open collector type (\*1) or voltage output type (\*2).

## Output waveform

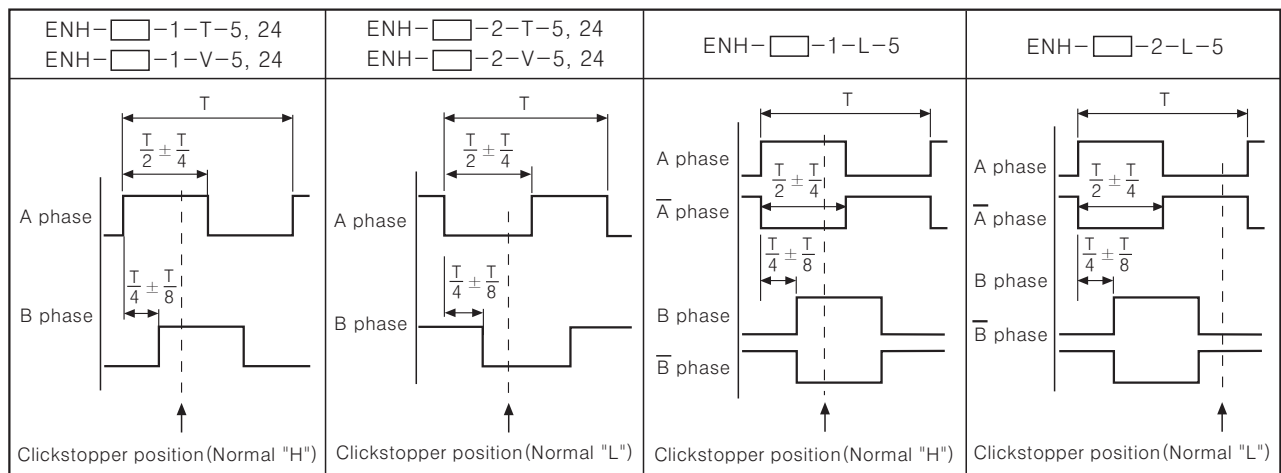

\*Clickstopper position Normal "H" or Normal "L": It shows the waveform when the handle is not stopped.

## Connections

●Totem pole output / Voltage output

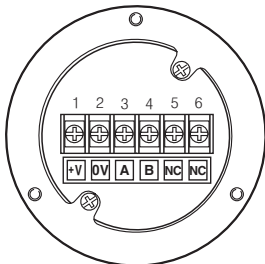

●Line driver output

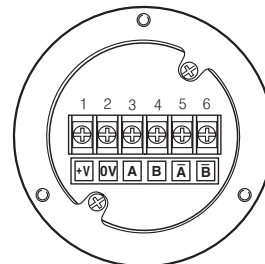

\*Do not use terminal No. 5, 6.

## Dimensions

