

# BF4R Series

## High reliability of fiber optic amplifier for convenient mounting

### ■ Features

- High speed response : Under 0.5ms
- Auto sensitivity setting (Button setting) / Remote sensitivity setting.
- External synchronization input, Mutual interference protection, Self-diagnosis.
- Reverse power polarity and short-circuit (Overcurrent) protection circuit
- Timer function : OFF Delay approx. 40ms fixed. (Standard Type, Remote sensitivity setting type only)
- Automatically selectable Light ON / Dark ON mode.
- Precise detection of small target and complicated place to install.



**!** Please read "Caution for your safety" in operation manual before using.



### ■ Specifications

Model	Standard type		External synchronization input type	Remote sensitivity setting type
	BF4RP/BF4GP	BF4R/BF4G	BF4R-E/BF4G-E	BF4R-R/BF4G-R
Response Frequency	Max. 0.5ms (FREQ.1), Max. 0.7ms (FREQ.2)			
Power voltage	12-24VDC ±10%, Ripple P-P: Max. 10%			
Current consumption	Max. 45mA			
Light source (Modulated light)	Red LED/Green LED (Modulated)			
Sensitivity adjustment	Selectable sensitivity adjustment button			
Operation mode	Automatic selection of Light ON/Dark ON accordance with button setting			
Control output	<b>PNP open collector output</b>	<b>NPN open collector output</b>		
	Load current: Max. 100mA Applied voltage: Max. 30VDC Output voltage: Min. (Power supply -2.5)VDC	Load current: Max. 100mA, Applied voltage: Max. 30VDC Residual voltage: Max. 1V (at 100mA load current), Max. 0.4V (at 16mA load current)		
Self-diagnosis output	ON state under unstable sensing (When the target stays for 300ms in unstable level), ON state when control output short-circuited			
	Load current: Max. 50mA Applied voltage: Max. 30VDC Output voltage: Min. (Power supply -2.5)VDC	Load current: Max. 50mA, Applied voltage: Max. 30VDC Residual voltage: Max. 1V (at 50mA load current), Max. 0.4V (at 16mA load current)		
Protection circuit	Reverse power polarity, Short-circuit (Overcurrent) protection circuit			
Indicator	Operation indicator: Red LED, Stability indicator: Green LED flash when the target stays in stable sensing level			
Input of stop transmission function	_____	_____	Includes	_____
External synchronization function	_____	_____	Includes (Gate/Trigger)	_____
Remote sensitivity setting function	_____	_____	_____	Includes
Interference prevention function	<b>(Note1)</b> Includes (Selectable FREQ.1 or FREQ.2 by ON/OFF button)			
Timer function (Selectable)	OFF delay timer (Approx. 40ms fixed)		_____	OFF delay timer (Approx. 40ms fixed)
Insulation resistance	Min. 20MΩ (at 500VDC mega)			
Ambient illumination	Sunlight : Max. 11,000lx, Incandescent lamp : Max. 3,000lx			
Noise strength	±240V the square wave noise (pulse width: 1μs) by the noise simulator			
Dielectric strength	1,000VAC 50/60Hz for 1 minute			
Vibration	1.5mm amplitude at frequency of 10 ~ 55Hz in each of X, Y, Z directions for 2 hours			
Shock	500m/s <sup>2</sup> (50G) in X, Y, Z direction for 3 times			
Operating temperature	-10 ~ +50°C (at non-freezing status)			
Storage temperature	-20 ~ +70°C (at non-freezing status)			
Ambient humidity	35 ~ 85%RH			
Material	Case : Heat-resistance ABS, Case cover : Polycarbonate			
Cable	φ 4, 4P, Length : 2m		φ 4, 6P, Length : 2m	
Approval	<b>CE</b>			
Unit weight	Approx. 65g			

※ **(Note1)** Frequency 1 (Normal mode) : Max. 0.5ms, Frequency : Max. 0.7ms

# Fiber Optic Amplifier

## Control output diagram

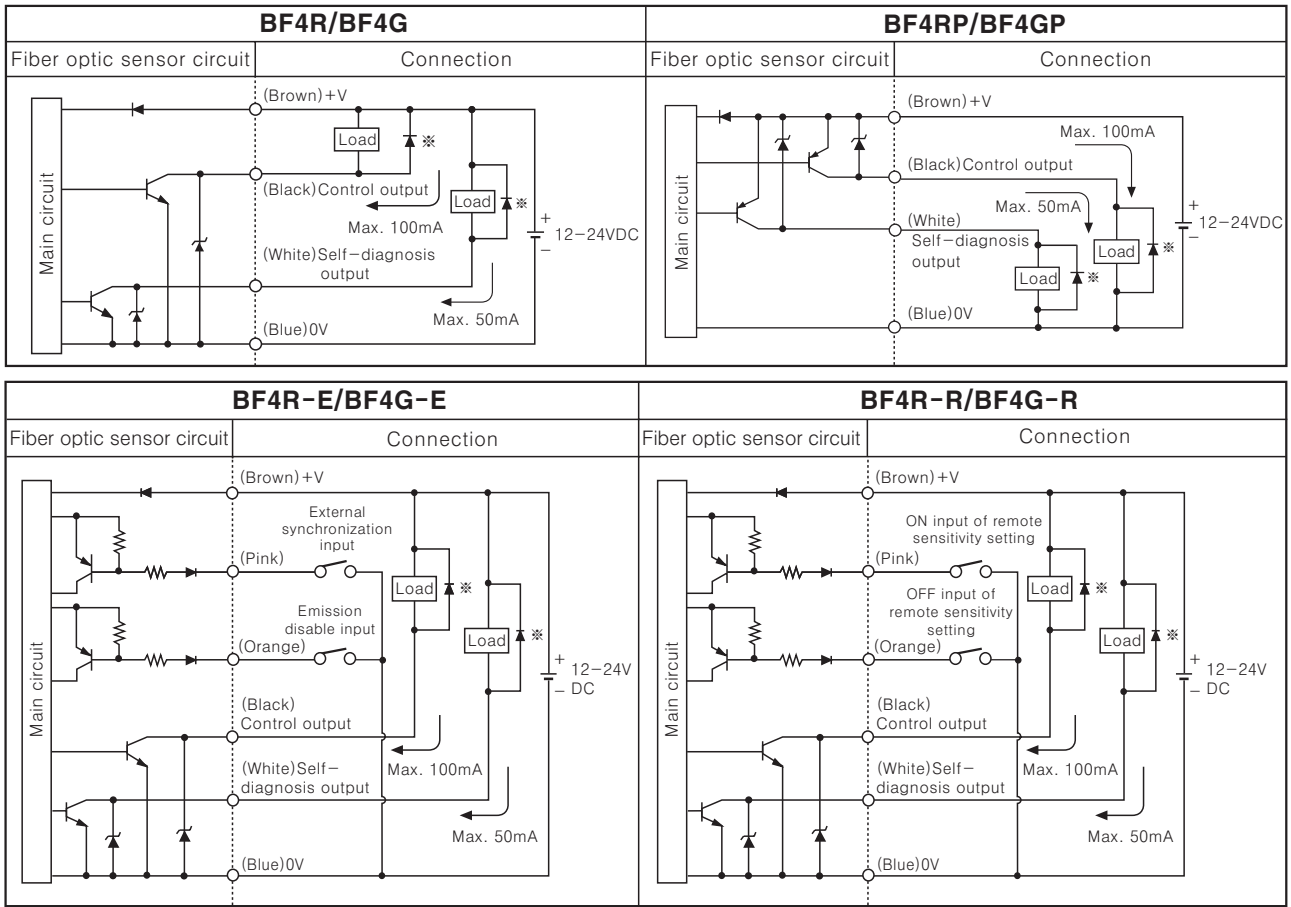

\* Connect Diode at external terminal for inductive load.

## Connections

### BF4R/BF4G

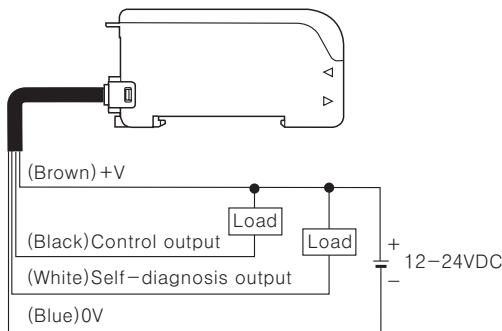

### BF4RP/BF4GP

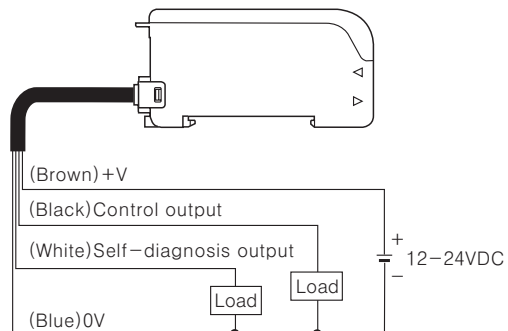

### BF4R-E/BF4G-E

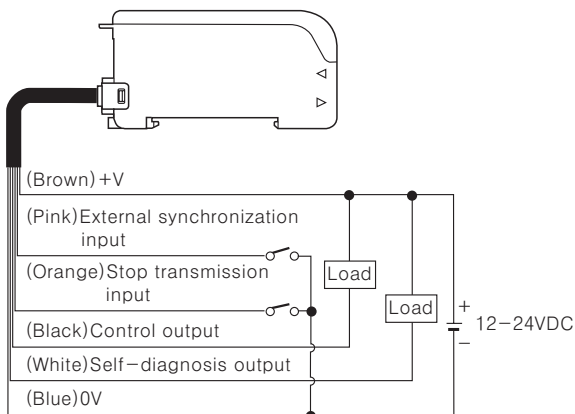

### BF4R-R/BF4G-R

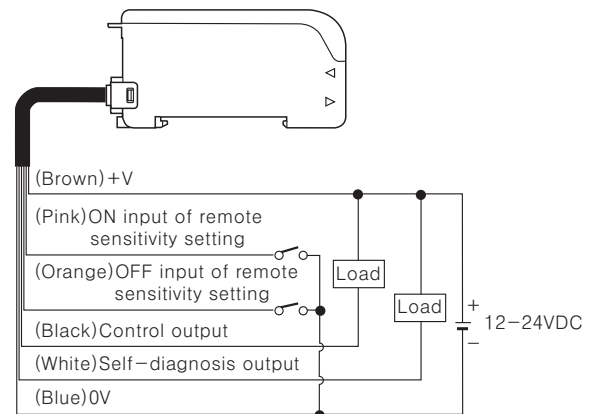

(A) Counter

(B) Timer

(C) Temp. controller

(D) Power controller

(E) Panel meter

(F) Tacho/Speed/Pulse meter

(G) Display unit

(H) Sensor controller

(I) Switching power supply

(J) Proximity sensor

(K) Photo electric sensor

(L) Pressure sensor

(M) Rotary encoder

(N) Stepping motor & Driver & Controller

(O) Graphic panel

(P) Production stoppage models & replacement

# BF4R Series

## Dimensions

(Unit:mm)

### ●Product

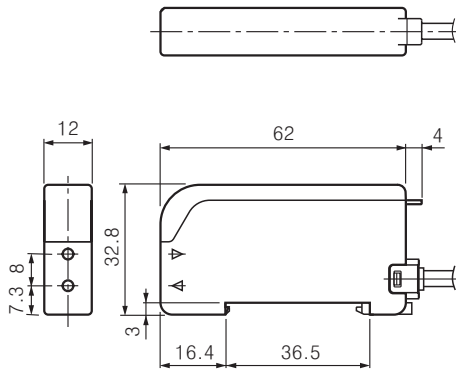

### ●Bracket

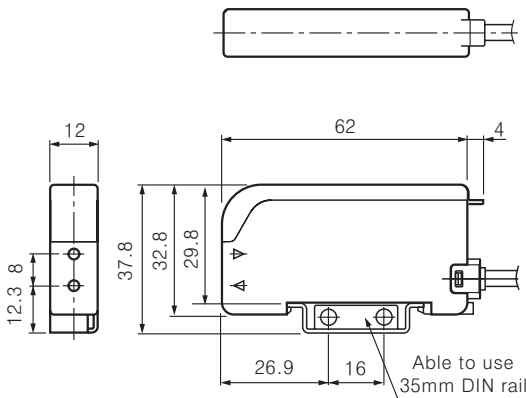

### ●Bracket

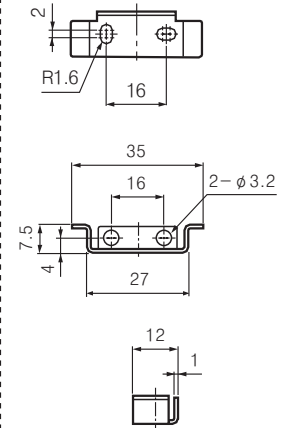

## Panel identification

### ●BF4R / BF4G / BF4RP / BF4GP / BF4R-R / BF4G-R

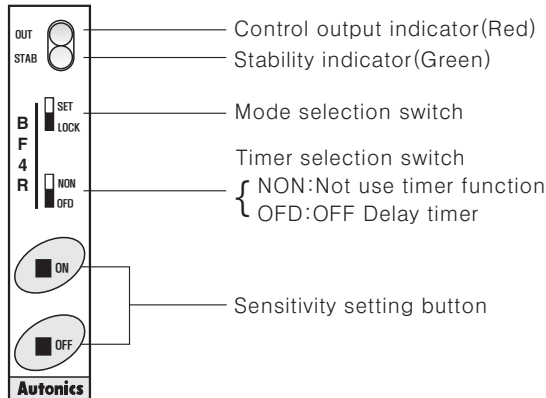

### ●BF4R-E / BF4G-E

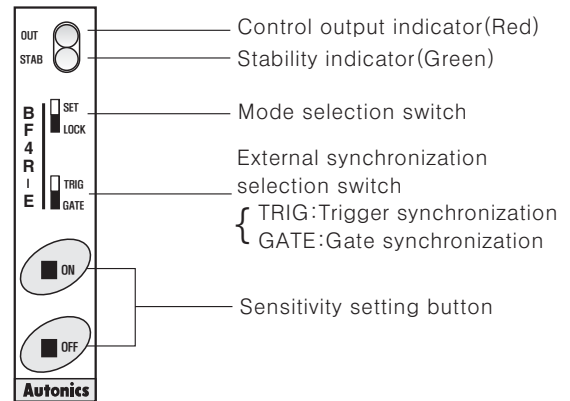

## Setting mode

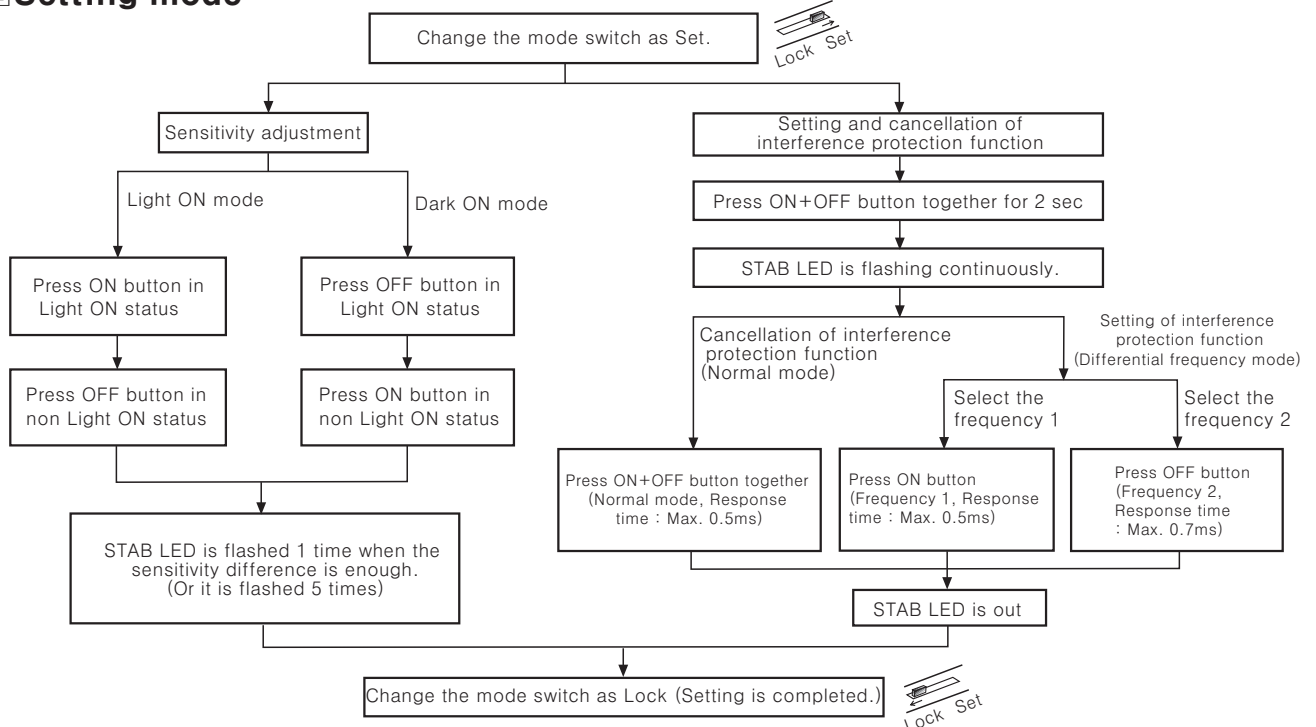





# Fiber Optic Amplifier

## ■ Sensitivity adjustment

### ○ Adjustment by the sensitivity setting button (Common)

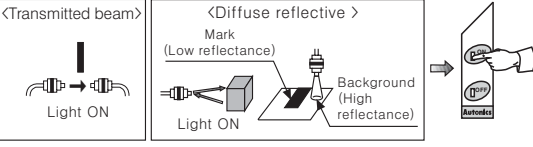
#### ● Light ON Mode

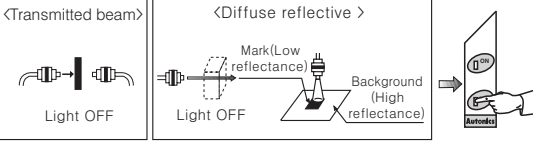
The control output turns on at Light ON status and turns off at Light OFF status.

Order	Setting method
①	Mount the fiber optic cable within sensing distance.
②	Change the mode selection switch to [SET]. 
③	Diffuse reflective: Press [ON] button with the sensing target in place. Transmitted beam: Press [ON] button without the sensing target. 
④	Stability indicator flashes at ON state. (Check the target position) 
⑤	Diffuse reflective: Press [OFF] button with the sensing target removed. Transmitted beam: Press [OFF] button with the sensing target in place. 
⑥	<ul style="list-style-type: none"> <li>When there is enough sensitivity difference between ON state and OFF state, the STAB indicator flashes one time only at stable sensing level.</li> <li>When there is not enough sensitivity difference between ON state and OFF state, the STAB indicator flashes five times at unstable sensing level. <b>(Note)</b></li> </ul>
⑦	Change the mode selection switch to [LOCK], even though the sensitivity setting button is touched, setting sensitivity shall not be changed. 

**(Note)** The sensitivity can be set at unstable sensing area.

#### ● Dark ON Mode

The control output turns off at Light ON status and turns on at Light OFF status.

#### <How to set sensitivity>

Most of adjustments except ③ & ⑤ are same as Light ON mode.

#### ③ state

- Diffuse reflective : Press [ON] button without the sensing target.
- Transmitted beam : Press [ON] button with the sensing target.

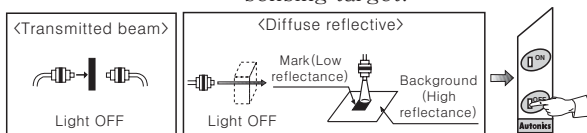

#### ⑤ state

- Diffuse reflective : Press [OFF] button with the sensing target.
- Transmitted beam : Press [OFF] button without the sensing target.

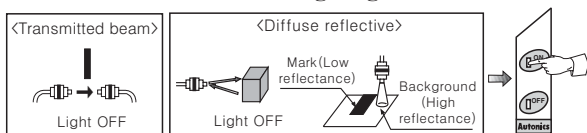

### ○ To set as max. sensitivity (Common)

① Set the mode selection switch to [SET] mode.

② If there is no sensing target,

**Light ON mode** : Press [ON → OFF] button

**Dark ON mode** : Press [OFF → ON] button

③ Set the mode selection switch to [LOCK] mode.

#### \* External sensitivity setting

##### ● Light ON Mode (From above ③)

External sensitivity setting **ON** input (High→Low→High),  
 External sensitivity setting **OFF** input (High→Low→High)

##### ● Dark ON Mode (From above ③)

External sensitivity setting **OFF** input (High→Low→High),  
 External sensitivity setting **ON** input (High→Low→High)

#### < Application >

- To extend sensing distance by the diffuse reflective type :

If fiber optic sensor is used in place where there are targets with high reflectivity and low reflectivity, able to get stable detection by adjusting max. sensitivity.

- When it is used as transmitted beam type at bad environment :

If fiber optic sensor is used in place where there is lots of dust or moisture it might cause malfunction. Please max. sensitivity then it can perform stable detection.

### ○ Remote adjustment of sensitivity (BF4R-R/BF4G-R)

BF4R-R/BF4G-R type can adjust the sensitivity with input signal lines regardless of the mode selection switch as following diagram;

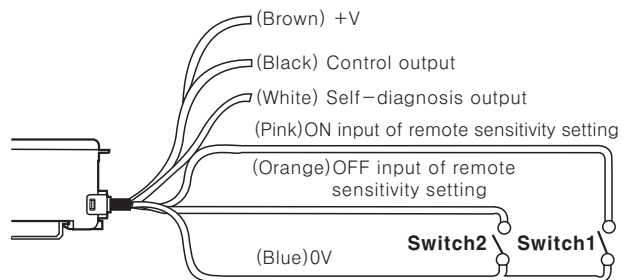

① Switch1 (ON input of remote sensitivity setting) :

Switch1 turns on and then turns off instead of ③ method by the sensitivity setting button.

② Switch2 (OFF input of remote sensitivity setting) :

Switch2 turns on and then turns off instead of ⑤ method by the sensitivity setting button.

#### < External sensitivity setting input signal condition >

State	Signal condition
High	4.5-30VDC or OPEN
Low	0-1VDC

\*Input impedance:10kΩ

(A) Counter

(B) Timer

(C) Temp. controller

(D) Power controller

(E) Panel meter

(F) Tacho/Speed/Pulse meter

(G) Display unit

(H) Sensor controller

(I) Switching power supply

(J) Proximity sensor

(K) Photo electric sensor

(L) Pressure sensor

(M) Rotary encoder

(N) Stepping motor & Driver & Controller

(O) Graphic panel

(P) Production stoppage models & replacement

# BF4R Series

## ○ Prohibition of inputting External sensitivity setting (BF4R-R/BF4G-R)

Even though mode switch is at Lock position, it is able to input external sensitivity setting when Switch1 and Switch2 are ON. Therefore please install Switch3 in order to prevent from malfunction as below.

- ※SW3 – OFF : Disable to set external sensitivity
- ※SW3 – ON : Enable to set external sensitivity

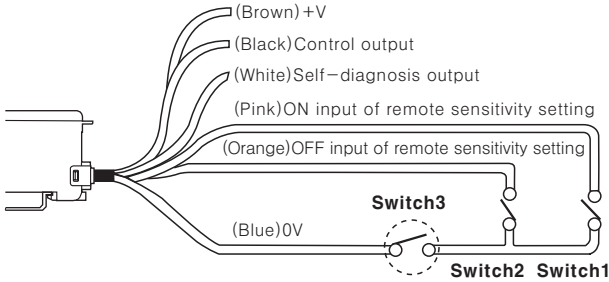

## ○ Answer Back function (BF4R-R/BF4G-R only)

When ON or OFF input of remote sensitivity setting is applied, after 300ms, self-diagnosis output turns on for 40ms and then the sensor keeps normal sensing state. (Note:Time chart)

- ※Self-diagnosis output does not turn on if there is no difference of sensitivity between ON input and OFF input and stable sensing is not executed, but stable sensing operates after 340ms.

<Time Chart : Light ON Mode >

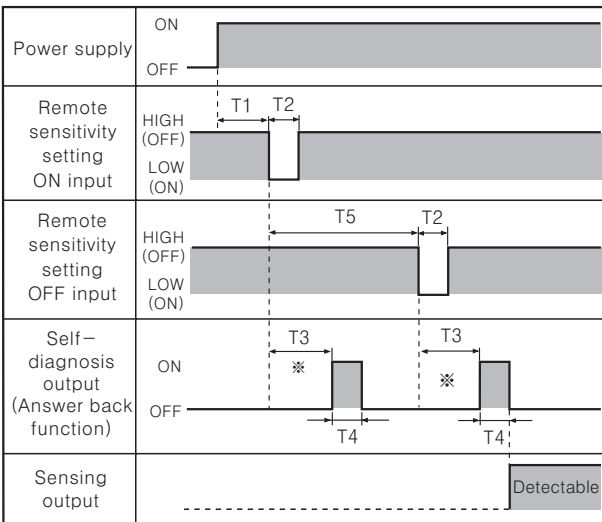

※During period T3 (Approx. 300ms), do not change the light ON value by moving the object, etc.

1. T1 ≥ 1,000ms (After the power turns on, it can be set after 1sec.)
2. T2 ≥ 5ms (ON or OFF input time of remote sensitivity setting must be min. 5ms)
3. T3 ≈ 300ms (When ON or OFF input of remote sensitivity setting is applied, self-diagnosis output turns on after 300ms)
4. T4 ≈ 40ms (ON time of self-diagnosis output)
5. T5 ≥ 500ms (When ON input of remote sensitivity setting is applied and then apply OFF input of remote sensitivity setting after 500ms)

## ■ OFF Delay timer function

(BF4R/BF4RP/BF4R-R/BF4G/BF4GP/BF4G-R)

Standard type and Remote sensitivity setting type both contain a built-in approx. 40ms fixed OFF-delay timer. The timer works when the timer selection switch is set to 'OFD'. The output is turned off after remaining on for additional 40ms at OFF position of the sensing output. It is useful when the response time of the connected device is slow or when the sensing signal from a tiny object is too short.

<Time chart>

T ≈ 40ms

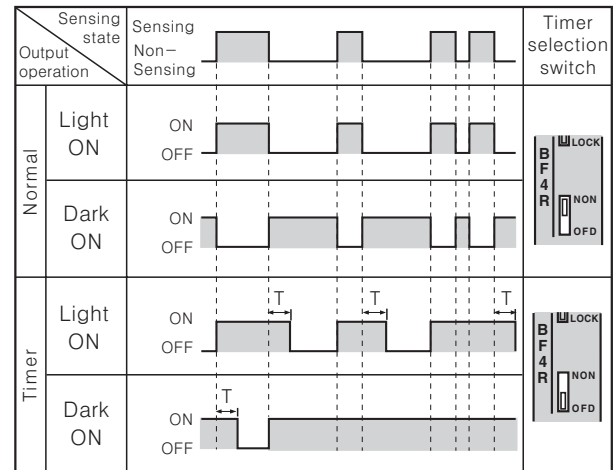

## ■ External synchronization input function (BF4R-E/BF4G-E)

By using external synchronization function, the time for making sensing can be specified by external synchronization. Trigger synchronization and gate synchronization are available.

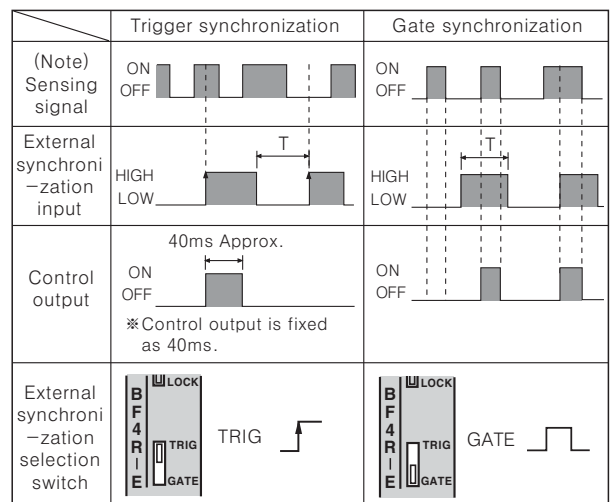

※T ≥ 0.5ms (When interference prevention function is used : T ≥ 0.7ms)

(Note) Actual signal detected by sensor.

<Input signal condition for External synchronization>

State	Signal condition
High	4.5–30VDC or Open
Low	0–1VDC

# Fiber Optic Amplifier

## ■ Stop transmission function (BF4R-E/BF4G-E)-Operation Test

- Below test is available under Light ON state only.
- If input of stop transmission is at Low state, transmission light will be stopped.
- It can check normal or abnormal state of the sensor without moving the target.

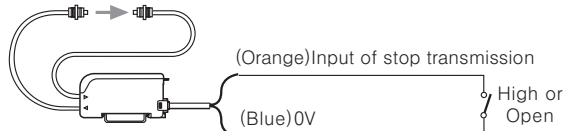

[ If input of stop transmission is at High or Open state, light is transmitted. ]

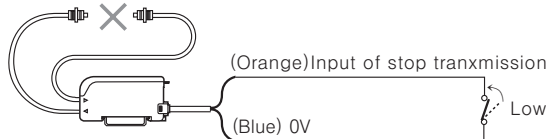

[ If input of stop transmission is at Low state, light is transmitted. ]

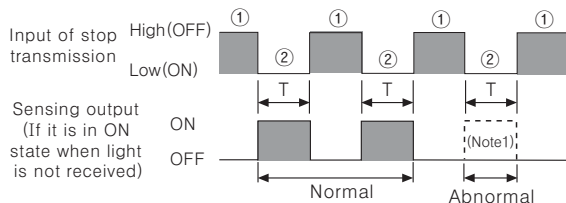

- ※ ① : Transmission area, ② : Stop transmission area
- ※ (Note1) If transmission is stopped control output must turn on, but if control output does not turn on, it seems that sensor has some problems.
- ※  $T \geq 0.5\text{ms}$   
(When using interference prevention function  $T \geq 0.7\text{ms}$ )
- ※ Input of stop transmission High: 4.5–30VDC or Open  
Low : 0–1VDC

## ■ Self-diagnosis function(Common)

When fiber hood is contaminated by dust, transmitted light is lowered by element ability loss or received light is lowered by missing of optical axis, the self-diagnosis output will turn on.

### ※ Light ON mode

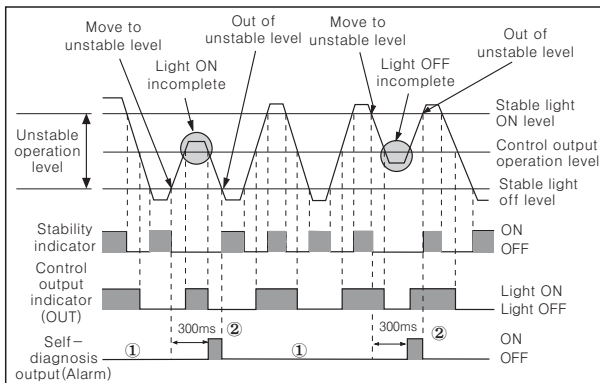

- ① The self-diagnosis output turns off during stable detection. (Above ①)
- ② When detecting state remains for 300ms at unstable level between stable light OFF level and stable light ON level, self-diagnosis output turns on, self-diagnosis output turns off at lower than stable light OFF level and upper than stable light ON level. (② position)
- ③ When the control output turns on, if an overcurrent condition exists in control output, then self-diagnosis output turns on.

## ■ Interference prevention function (Common)

BF4R series has interference prevention function, two fiber optic cables can be mounted very closely by setting different transmission frequencies.

### ● Interference prevention function (Operation of differential frequency mode)

First sensor—FREQ.1 (Response time:Max. 0.5ms)

- ① Set the mode selection switch to [SET].

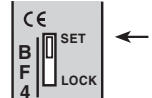

- ② Press [ON] & [OFF] buttons for 2sec. at the same time.
- ③ The [STAB] indicator flashes continuously.
- ④ Press [ON] button
- ⑤ The [STAB] indicator turns off.

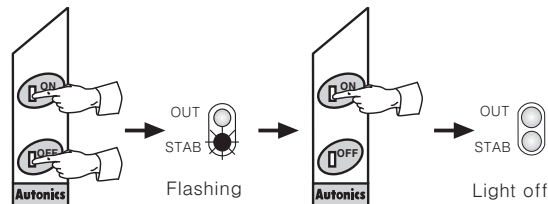

- ⑥ Set the mode selection switch to [LOCK].

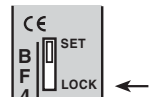

Second sensor—FREQ.2 (Response time:Max. 0.7ms)

- ① Set the mode selection switch to [SET].



- ② Press [ON] & [OFF] buttons for 2sec. at the same time.
- ③ The [STAB] indicator flashes continuously.
- ④ Press [OFF] button
- ⑤ The [STAB] indicator turns off.

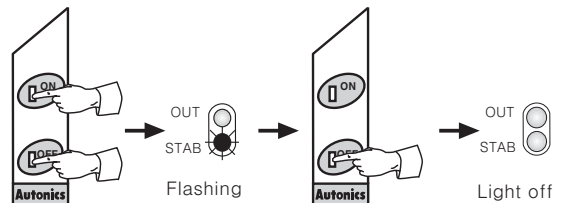

- ⑥ Set the mode selection switch to [LOCK].



### ● Interference prevention function (Operation of normal mode)

- ① Set the mode selection switch to [SET].
  - ② Press [ON] & [OFF] buttons for 2 sec. at the same time.
  - ③ The stable indicator flashes continuously.
  - ④ Press [ON] & [OFF] buttons at the same time.
  - ⑤ The [STAB] indicator turns off.
  - ⑥ Set the mode selection switch to [LOCK].
- ※ When interference prevention function is used, hysteresis & response time will be longer than normal operation (Response time:Max. 0.5ms).

(A)	Counter
(B)	Timer
(C)	Temp. controller
(D)	Power controller
(E)	Panel meter
(F)	Tacho/Speed/Pulse meter
(G)	Display unit
(H)	Sensor controller
(I)	Switching power supply
(J)	Proximity sensor
(K)	Photo electric sensor
(L)	Pressure sensor
(M)	Rotary encoder
(N)	Stepping motor & Driver & Controller
(O)	Graphic panel
(P)	Production stoppage models & replacement