

## Auto door sensor

### ■ Features

- Stop time selection function  
(Selectable stop time 2 / 7 / 15sec.)
- 4 steps variable function for front sensing area  
(7.5°, 14.5°, 21.5°, 28.5° 4steps variable)
- Right/Left sensing area elimination function
- Power supply  
(24-240VAC/24-240VDC, 12-24VAC/12-24VDC)
- Built-in Microprocessor



**⚠ Please read "Caution for your safety" in operation manual before using.**

### ■ Specifications

Model	ADS-AF	ADS-AE
Cover color	Silver	
Power supply	24-240VAC ±10% 50/60Hz, 24-240VDC ±10% (Ripple P-P:Max. 10%)	12-24VAC ±10% 50/60Hz, 12-24VDC ±10% (Ripple P-P:Max. 10%)
Power consumption	Max. 4VA at 240VAC	Max. 2VA at 24VAC
Control output	(*1) Relay contact output [ Relay contact capacity : 50VDC 0.1A (Resistive load) Relay contact composition : 1a	
Relay life cycle	Mechanical : Min. 20,000,000, Electrical : Min. 50,000	
Mounting height	2.0m ~ 2.7m (Max. sensing distance : 3m)	
Sensing method	Infrared reflection method (Diffuse reflective type)	
Output delay time	Time delay approx. 0.5sec.	
Output holding time	Selectable 2 / 7 / 15sec. by slide switch	
Interference prevention	H, L (Interference prevention switch)	
Front sensing area	7.5°, 14.5°, 21.5°, 28.5° : Set angle by adjuster	
Adjustable sensing area	(1, 2, 3 Area), (7, 8, 9 Area) Eliminate each by each : Adjustment with switch for eliminate Right/Left sensing area	
Light source	Infrared chip diode (modulated)	
Indicator	Power on : Green LED turns on, Sensing : Red LED turns on	
Connection method	Connector wire connection	
Insulation resistance	Min. 20MΩ (at 500VDC mega)	
Noise strength	±2,000V the square wave noise (pulse width:1μs) by the noise simulator	
Dielectric strength	1,000VAC 50/60Hz for 1 minute	
Vibration	1.5mm amplitude at frequency of 10 ~ 55Hz in each of X, Y, Z directions for 2 hours	
Shock	100m/s <sup>2</sup> (Approx. 10G) in X, Y, Z directions for 3 times	
Ambient illumination	Sunlight : Max. 11,000lx, Incandescent lamp : Max. 3,000lx	
Ambient temperature	-20°C ~ +50°C (at non-freezing status), Storage : -20 ~ +70°C	
Ambient humidity	35 ~ 85%RH, Storage : 35 ~ 85%RH	
Accessory	Cable : 2.5m, Mounting screw : 2EA, Mounting template	
Protection	IP50 (IEC standard)	
Material	Case : ABS, Lens : Acrylic, Lens cover : Acrylic	
Unit weight	Approx. 320g	

**\*(\*1) Do not use Load which is beyond the rated capacity of contact point of Relay.**

It can cause bad insulation, contact fusion, bad contact, relay breakdown, and fire etc.

- (A) Counter
- (B) Timer
- (C) Temp. controller
- (D) Power controller
- (E) Panel meter
- (F) Tacho/Speed/Pulse meter
- (G) Display unit
- (H) Sensor controller
- (I) Switching power supply
- (J) Proximity sensor
- (K) Photo electric sensor
- (L) Pressure sensor
- (M) Rotary encoder
- (N) Stepping motor & Driver & Controller
- (O) Graphic panel
- (P) Production stoppage models & replacement

# ADS-A

## Parts description

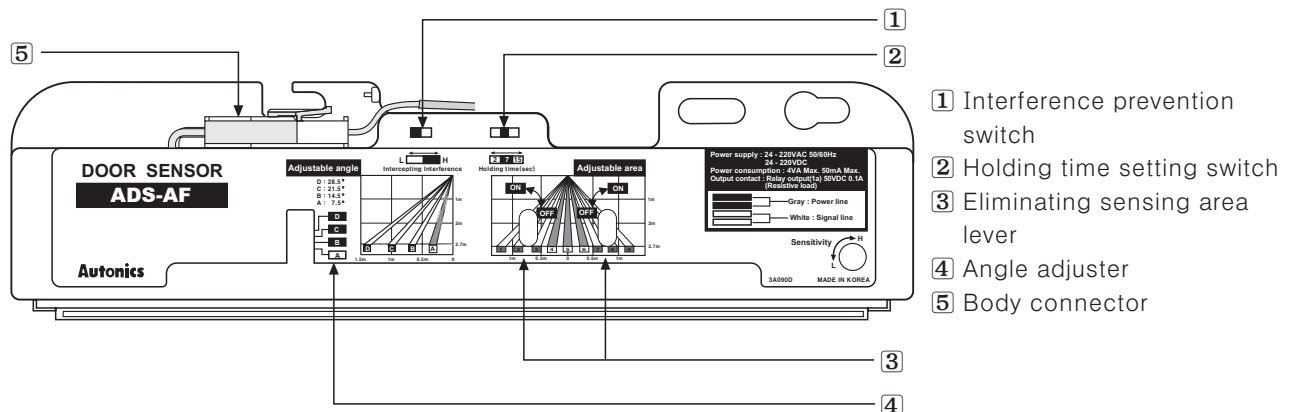

## Dimensions

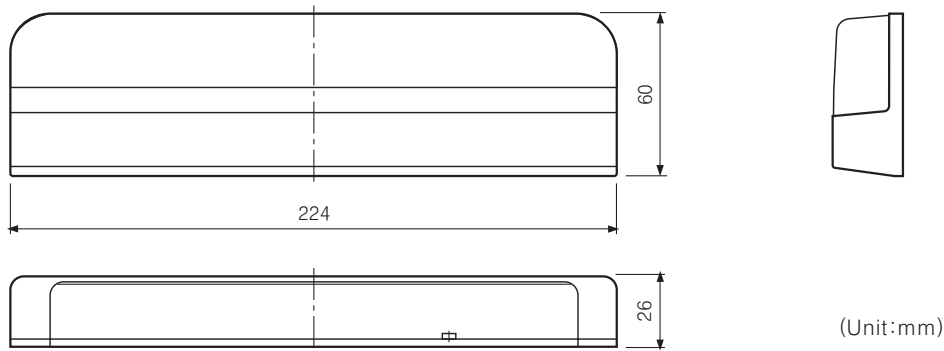

## Installation

Installation	⚠ Caution
<p><b>1. Attach mounting template at mounting position</b>                      (Mounting height : 2.0m ~ 2.7m)</p> <ul style="list-style-type: none"> <li>• Drill <math>\phi 3.4</math>mm hole based on mounting template.</li> <li>• In case of wiring the cable on the wall to hide the cable, drill <math>\phi 9</math>mm hole.</li> <li>• Install the unit after removing the mounting template.</li> </ul> <p>Hole for inner cable connection</p> <p>Max. 2.7m</p> <p>Center</p> <p>Mounting hole</p> <p>Mounting template</p>	<p><b>⚠ Warning</b>     <b>It may give an electric shock.</b></p> <ul style="list-style-type: none"> <li>• When this unit is used with cable outlet removed from cover, it must be installed indoors.                      (Electric shock or damage can occur if water flows through cable outlet.)</li> </ul> <p><b>⚠ Caution</b>     <b>People can be jammed in the door.</b></p> <ul style="list-style-type: none"> <li>• If unit is installed higher than 2.7m in height, it may not detect short children.</li> <li>• If unit is installed lower than 2.0m in height, it may not work properly.</li> </ul>

# Auto Door Sensor

## Installation

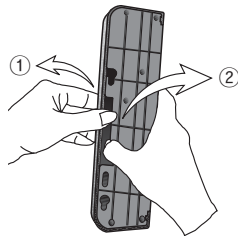
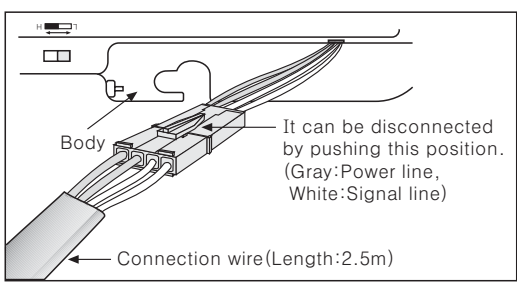
Installation	⚠ Caution
<p><b>2. Please install this unit with mounting screws after removing protection cover.</b></p> 	<p><b>⚠ Caution Mounting the unit</b></p> <ul style="list-style-type: none"> <li>Do not put excessive tightening torque on screw bolt when mounting this unit. It may result in mounting hole damage.</li> </ul> <p><b>&lt;Protection cover detachment&gt;</b></p> <ul style="list-style-type: none"> <li>Pulling left thumb toward ①, key lock will be released and pull right thumb toward ②, protection cover and body will be detached.</li> </ul>
<p><b>3. The code part of wiring code should be connected to main control part.</b></p> <ul style="list-style-type: none"> <li>Install the connector to be connect to the body.</li> </ul>	
<p><b>4. Connect the extension cable and the main controller.</b></p> 	<p><b>⚠ Caution Connection of the connector</b></p> <ul style="list-style-type: none"> <li>Plug in the connector of the extension cable and the connector of the unit completely. The unit may not work normally with inferior contact.</li> </ul>

## Adjustment

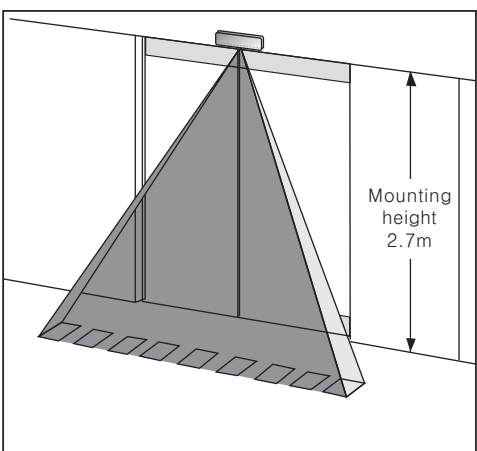
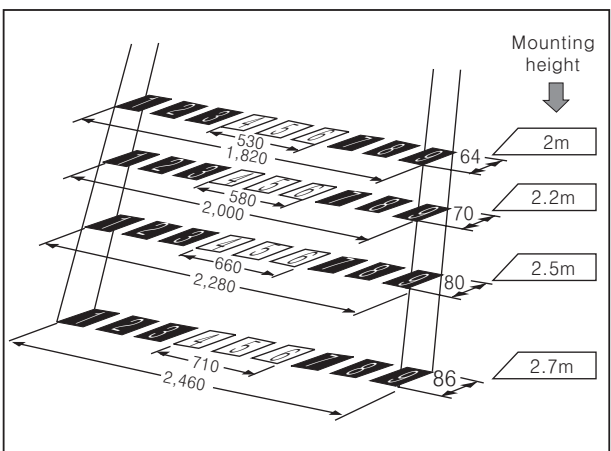
Please turn on the power.	
<p><b>1. Check of the sensing area</b></p> <p>This characteristic of the sensing area is shown in below chart and drawing.</p> 	<p>(Unit:mm)</p> 

- (A) Counter
- (B) Timer
- (C) Temp. controller
- (D) Power controller
- (E) Panel meter
- (F) Tacho/ Speed/ Pulse meter
- (G) Display unit
- (H) Sensor controller
- (I) Switching power supply
- (J) Proximity sensor
- (K) Photo electric sensor
- (L) Pressure sensor
- (M) Rotary encoder
- (N) Stepping motor & Driver & Controller
- (O) Graphic panel
- (P) Production stoppage models & replacement

## Adjustment

### 2. Adjustable sensing area

Adjustable 7° in each step.  
(Sensing area angle step : 7.5° ~ 28.5°)

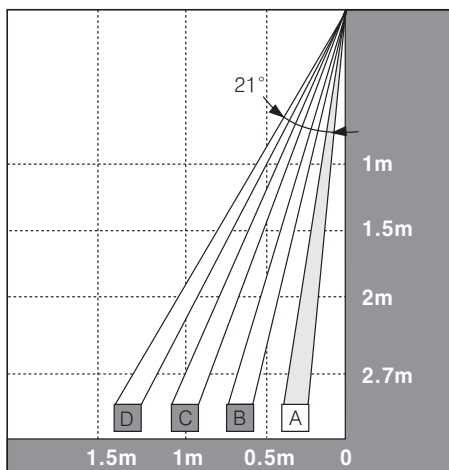
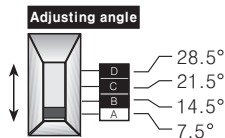

### ⚠ Caution People can be jammed in the door.

- Be sure to install an auxiliary photo sensor as the safe equipment.  
ADS-SE series is available for additional sensor. (door side sensor)
- Even if the unit is installed at the closest side from the door, the rail of the door is dangerous.

### 3. Adjustment of Left, Right sensing area width

Sensing area width ①②③ can be eliminated by left lever, ⑦⑧⑨ by right lever.

- Use the unit as removing non-sensing area by the lever adjusting width at narrow sensing area.
- ※ Turn the adjuster till it stops it toward arrow direction by a (-) driver.

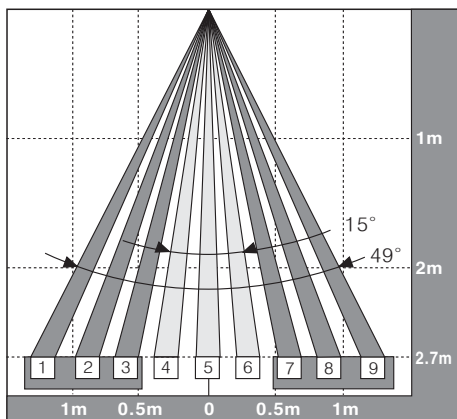
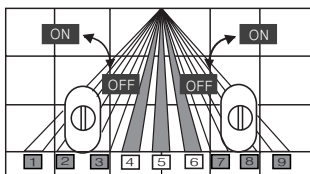

### ⚠ Caution People can be run against the door.

- When eliminating the Right/Left sensing range, be sure to install the unit at place where a person approaches at the front of the door.  
In case of eliminating sensing area width:
- If a person approaches at the side of the door, they may not be detected and the door will not open.
- The sensing range for position of eliminating lever is as below.

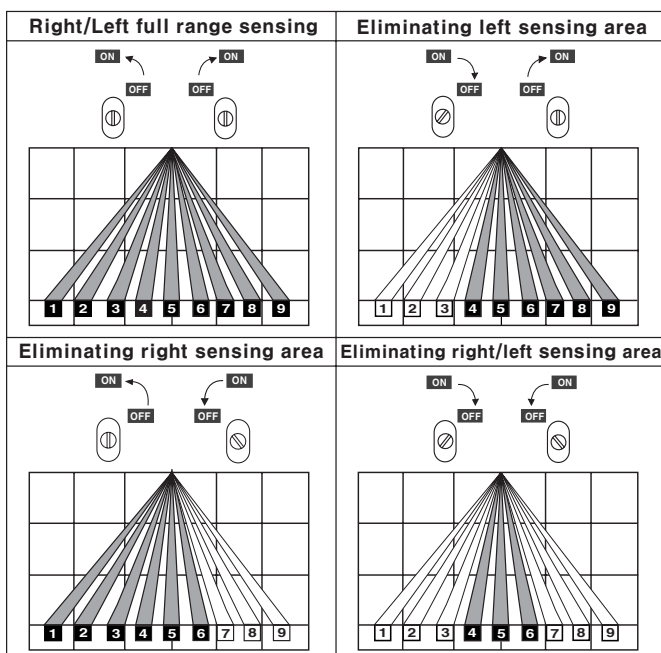

※ It is not able to eliminate individual areas like elimination of area ① or ⑦.

## Adjustment

### 4. How to set the switch for interference prevention

In case of using several door sensors adjacently, please set the interference prevention switches of the sensors differently.

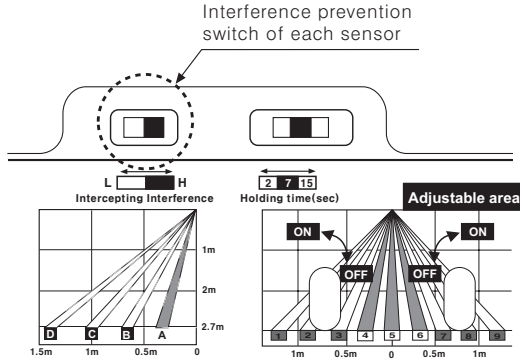

### ⚠ Caution Door can be opened and closed

When several door sensors are installed simultaneously without considering any interference prevention, it may cause malfunction by another door sensor even though no moving object is existed.

#### < Interference prevention >

If sensing area of the door sensors is overlapped, set each switch in difference or install the unit on non-overlapped sensing area.

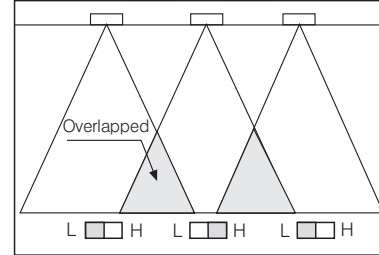

### 5. Holding time switch setting

It is able to set the holding time by the holding time switch. (Selectable 2 / 7 / 15sec.)

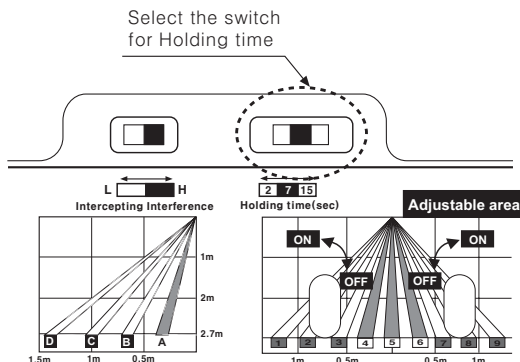

### ⚠ Caution People can be jammed in the door.

- Be sure to install a auxiliary sensor as a safe equipment. There is ADS-SE series for a Door side sensor.
- The door will close after the time set by the holding time switch has elapsed.

#### <Holding time>

- When people or objects stay in sensing area after auto tuning (Set 7sec. for Holding time), it will detect the stationary people or objects for set time by the holding time switch, and then the sensor's output turns off after set time.

### 6. Sensitivity Setting

Even though people in the sensing area, if the sensor does not operate, turning the adjuster up to H. The sensitivity will be increased.



Even though people in the sensing area, if the sensor operated, turning the adjuster up to L. The sensitivity will be decreased.

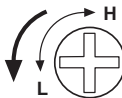

### ⚠ Caution Door can be opened and closed

Please check the normal operation by turning the power ON/OFF after finishing the sensitivity setting. It may not operate normally because the install setting is changed before and after sensitivity setting.

### 7. Protection cover

- Mount the cover on the unit.
- In case of using outlet to wire exposed cable, remove the cable outlet as below.

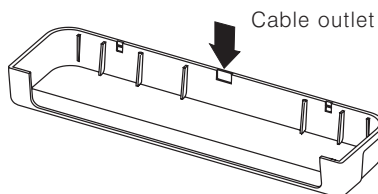

### ⚠ Warning It may give an electric shock.

- Do not take off its cover on operating the unit.
- In case of using the cable outlet, the unit must be installed in inner position of door.
- If water is penetrated into the cable outlet, it may cause human injury or give an electric shock.

(A)	Counter
(B)	Timer
(C)	Temp. controller
(D)	Power controller
(E)	Panel meter
(F)	Tacho/Speed/Pulse meter
(G)	Display unit
(H)	Sensor controller
(I)	Switching power supply
(J)	Proximity sensor
(K)	Photo electric sensor
(L)	Pressure sensor
(M)	Rotary encoder
(N)	Stepping motor & Driver & Controller
(O)	Graphic panel
(P)	Production stoppage models & replacement

## ■ Adjustment

<b>7. Sensitivity</b> After turning on the power, please stand by in the condition without moving object in the sensing area.		• If it is not passed for 3 sec after turning the power, holding detection is impossible				
<b>8. Check of sensing operation</b> Check sensing operation as follow drawing.						
Entry activation						
Operation indicator	Orange	LED ON	LED OFF	LED OFF	LED OFF	LED OFF
	Green	LED OFF	LED ON	LED OFF	LED ON	LED ON
	Red	LED OFF	LED OFF	LED ON	LED OFF	LED OFF
Output contact		OFF	OFF	ON	Output : ON for holding time	Output : OFF after 0.5sec.
<b>9. Maintenance</b> <ul style="list-style-type: none"> <li>• If the sensing lens is unclean, the unit may cause malfunction, in this case, please clean it with dry tissue and natural detergent.</li> <li>• Do not use an organic cleaner such as benzene, etc.</li> </ul>				<b>⚠ Caution</b> It may give an electric shock. <ul style="list-style-type: none"> <li>• Do not wash the unit with water.</li> <li>• Do not repair or disassemble the unit.</li> </ul>		

## ■ Trouble shooting

Trouble	Check	Correction action
It does not work.	<ul style="list-style-type: none"> <li>● Power supply</li> <li>● Cable disconnection, incorrect connection</li> </ul>	<ul style="list-style-type: none"> <li>● Adjust the power cable with the rated voltage.</li> <li>● Check connector and wiring.</li> </ul>
Sometimes it does not work.	<ul style="list-style-type: none"> <li>● The sensing lens is unclean</li> </ul>	<ul style="list-style-type: none"> <li>● Clean the lens with dry tissue and natural detergent.</li> </ul>
The door is opened even if people do not enter in sensing area.	<ul style="list-style-type: none"> <li>● There are moving objects.</li> <li>● By occurring sudden change of the sensing area.</li> <li>● Sensing area is overlapped.</li> <li>● There is equipment causing strong electric wave, noise.</li> <li>● A drop of water is placed at the lens.</li> </ul>	<ul style="list-style-type: none"> <li>● Check the status of installation.</li> <li>● Check surrounding environment for installation.</li> <li>● Install the unit to avoid overlap for sensing area.</li> <li>● Set the switch intercepting interference.</li> <li>● Do not install the equipment producing strong noise near the sensor.</li> <li>● Remove a drop of water.</li> </ul>

# Auto Door Sensor

## ■ Installation environment

1. This product is not qualified for waterproof. Please install without being directly contacted with rain or snow. It may cause breakdown and short circuit.

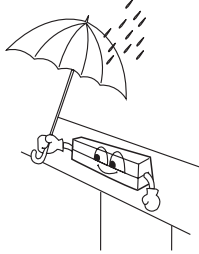

2. Don't install in the place where having reflecting light like sunshine directly reaches. It may does not operate normally.

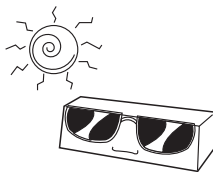

3. Don't install in the place where smoke and vapor occurs. It may don't operate normally.

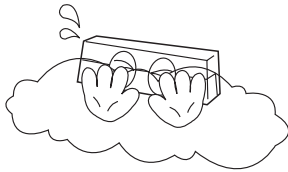

4. If you place a movable object in the sensing area, it may cause malfunction by sensing the object because of natural phenomenon like wind etc.



5. Sensing hole must face the bottom, or the sensor doesn't operate normally.

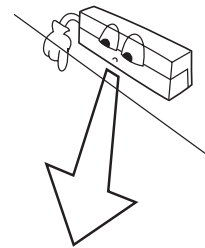

## ■ Caution for using

### ⚠ Warning It may give an electric shock.

Do not take off its cover when the unit is operating. If water is penetrated into the cable outlet, it may cause human injury or give an electric shock.

- When using this unit with cable outlet removed, this unit must be installed indoors. If installing it outdoors, it may give an electric shock or damage by direct contact with water when the water inflows through cable outlet.
- Do not wash the unit with water. Be careful not the water inflow into this unit. It may cause damage or give an electric shock.
- Do not repair or disassemble the sensor. It may cause damage or give an electric shock.

### ⚠ Caution Be careful of human injury by the door.

- Do not install this unit at place higher than 2.7m. It may not sense small children due to lack of sensitivity.
- Do not install this unit under 2m. It may not operate normally.
- Please install photo sensor as the safety equipment. It is hard to detect the closest area from a door. It may not be able to detect children or old people continuously and they can be jammed in the door.
- Please install photo sensor as the safety equipment. This unit holds the door for Holding time. When the Holding time passed, the door will be closed. People may be jammed in the door.

### ⚠ Caution Door may not open

- When eliminating the Right/Left sensing area, be sure to make the object from the front of the door. When eliminating the Right/Left sensing area, it is hard to detect the enter from the width direction, it may cause human injury because the door is not opened.

### ⚠ Caution It may cause malfunction.

- When wiring the photoelectric sensor with high voltage line, power line in the same conduit, it may cause malfunction. Therefore please wire separately or use different conduit.
- Do not install this unit at place where there is dust or corrosive gas.
- The wire connection shall be used as short as possible in order to avoid malfunction by surge.
- When it is covered by dirt at lens, please clean the lens with dry cloth, but do not use any organic materials such as alkali, acid, chromic acid.

(A) Counter

(B) Timer

(C) Temp. controller

(D) Power controller

(E) Panel meter

(F) Tacho/Speed/Pulse meter

(G) Display unit

(H) Sensor controller

(I) Switching power supply

(J) Proximity sensor

(K) Photo electric sensor

(L) Pressure sensor

(M) Rotary encoder

(N) Stepping motor & Driver & Controller

(O) Graphic panel

(P) Production stoppage models & replacement