

BJ Series

Compact and Long sensing distance/Micro spot type

Features

Long distance sensing type

- Long sensing distance with high quality lens
- Detects up to 15m (Transmitted beam type)
- Long sensing distance : Diffuse reflective type 1m, Polarized reflective type 3m (MS-2A)
- M.S.R (Mirror Surface Rejection) function (Polarized retroreflective type)

Transparent glass sensing type / Micro spot type

- Stable detection for transparent object (LCD, PDP, glass etc) by BJG30-DDT.
- Easy to check sensing location with Red LED
- Suitable for sensing small objects (Min. sensing object: $\varnothing 0.2\text{mm}$ pure copper wire)

⚠ Please read "Caution for your safety" in operation manual before using.

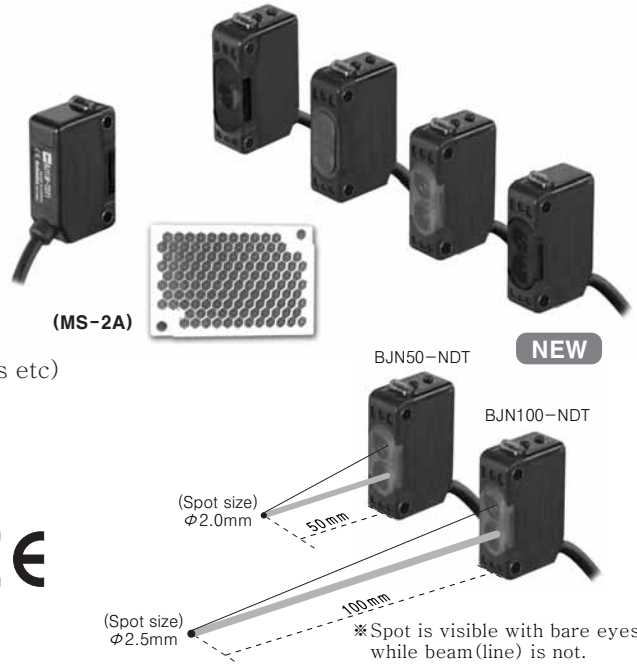

Specifications

Model	NPN Open collector output	BJ15M-TDT	BJ10M-TDT	BJ3M-PDT	BJ1M-DDT	BJ300-DDT	BJ100-DDT	BJG30-DDT
Model	PNP Open collector output	BJ15M-TDT-P	BJ10M-TDT-P	BJ3M-PDT-P	BJ1M-DDT-P	BJ300-DDT-P	BJ100-DDT-P	—
Sensing type	Transmitted beam		Polarized retroreflective		Diffuse reflective			
Sensing distance	0~15m	0~10m	0.1~3m(★)		0~1m	0~300mm	0~100mm	0~30mm
Sensing target	Opaque material over $\varnothing 12\text{mm}$		Opaque material over $\varnothing 75\text{mm}$		Non-glossy white paper 300×300mm	Non-glossy white paper 100×100mm		Transparent glass 50×50mm (t=3.0mm)
Hysteresis	—		Max. 20% at rated setting distance					
Response time	Max. 1ms							
Power supply	12~24VDC $\pm 10\%$ (Ripple P-P: Max.10%)							
Current consumption	Emitter/Receiver:Max. 20mA			Max. 30mA				
Light source	Infrared LED (850nm)	Red LED (660nm)	Red LED (660nm)	Infrared LED (850nm)	Red LED (660nm)	Infrared LED (850nm)	Infrared LED (850nm)	
Sensitivity adjustment	Short rotation VR (210°)							—
Operation mode	Light ON/Dark ON selectable							Light ON mode fixed
Control output	NPN open collector output							
	• Load voltage : Max. 26.4VDC • Load current : Max. 100mA • Residual voltage : Max. 1V							
Protection circuit	Reverse polarity protection, Output short-circuit protection			Reverse polarity protection, Interference prevention function, Output short-circuit protection				
	• Load voltage : Max. 26.4VDC • Load current : Max. 100mA • Residual voltage : Min. (Power supply-2.5V)							
Indicator	Operation : Red, Stable : Green (Emitter's power indicator : Green)							
Connection	Outgoing cable type							
Insulation resistance	Max. 20M Ω (at 500VDC)							
Dielectric strength	1000VAC 50/60Hz for 1minute							
Vibration	1.5mm or 300mm amplitude at frequency of 10 ~ 55Hz in each of X, Y, Z directions for 2 hours							
Shock	500m/s ² X, Y, Z directions for 3 times							
Ambient illumination	Sunlight : Max. 11,000lx, Incandescent lamp : Max. 3,000lx (Receiver illumination)							
Ambient temperature	-25 ~ 55°C (Storage : -40 ~ 70°C) at non-freezing status							
Ambient humidity	35 ~ 85%RH (at non-freezing status)							
Protection	IP65 (IEC standard)							
Material	Case : PC+ABS, Lens : PMMA, LED Cap : PC							
Cable	$\varnothing 3.5\text{mm}$, 3P, Length : 2m (Emitter of transmitted beam type : $\varnothing 3.5\text{mm}$, 2P, Length : 2m)							
Accessory	Common	Fixing bracket, Bolt, Adjustment driver						Fixing bracket, Bolt
	Individual	—	Reflector (MS-2A)	—				—
Approval	CE							
Unit weight	Approx. 90g		Approx. 60g		Approx. 45g			—

※ (★) The sensing distance is extended to 0.1~4m or 0.1~5m when using optional reflector MS-2S or MS-3S.

Long sensing distance/Micro spot type

■ Specifications

Model	NPN open collector output	BJN50-NDT	BJN100-NDT
	PNP open collector output	BJN50-NDT-P	BJN100-NDT-P
Sensing type	Diffuse reflective (Narrow beam)		
Power supply	12-24VDC ±10% (Ripple P-P : Max.10%)		
Current consumption	Max. 30mA		
Min. diameter of transmitting SPOT	Approx. ϕ 2.0mm		Approx. ϕ 2.5mm
Min. sensing target	Approx. min. ϕ 0.2mm (Copper wire)		
Sensing target	Transparent, Translucent, Opaque materials		
Sensing distance	30~70mm (100×100mm Non-glossy white paper)		70~130mm (100×100mm Non-glossy white paper)
Hysteresis	Max. 25% at sensing distance		Max. 20% at sensing distance
Light source / Wavelength	Pin Point LED(Point source) / 650nm		
Control output	NPN or PNP Open collector type • Load voltage : Max. 26.4VDC • Load current : Max. 100mA • Residual voltage \Rightarrow NPN : Max. 1V, PNP : Min. (Power voltage -2.5V)		
Operation mode	Light ON / Dark ON selectable (Short rotator adjuster)		
Protection circuit	Reverse polarity protection, Output short-circuit protection, Interference prevention function		
Response time	Max. 1ms		
Sensitivity adjustment	Short rotation VR(210°)		
Ambient illumination	Sunlight : Max. 11,000lx, Incandescent lamp : Max. 3,000lx (Receiver illumination)		
Ambient temperature	Operation: -25~55°C, Storage: -40~70°C (at non-freezing, non-dew status)		
Ambient humidity	Operation & Storage : 35~85%RH (at non-dew status)		
Insulation resistance	Min. 20M Ω (500VDC)		
Dielectric strength	1,000VAC 50/60Hz for 1minute		
Vibration	1.5mm or 300m/s ² amplitude at frequency of 10~55Hz in each of X, Y, Z directions for 2 hours		
Shock	500m/s ² X, Y, Z directions for 3 times		
Protection	IP65 (IEC standard)		
Connection	Outgoing cable type		
Indicator	Operation indicator : Red, Stability indicator : Green		
Material	Case : PC+ABS, Lens : PMMA, LED CAP : PC		
Cable	ϕ 3.5mm, 3P, Length : 2m		
Accessory	Mounting bracket, Bolt, Adjustment driver		
Approval	CE		
Unit weight	Approx. 45g		

■ Feature data

○ Transmitted beam type

● BJ15M-TDT / BJ15M-TDT-P / BJ10M-TDT / BJ10M-TDT-P

Parallel shifting characteristic		Angle characteristic	
Measuring method	Data	Measuring method	Data

(A) Counter
(B) Timer
(C) Temp. controller
(D) Power controller
(E) Panel meter
(F) Tacho/Speed/Pulse meter
(G) Display unit
(H) Sensor controller
(I) Switching power supply
(J) Proximity sensor
(K) Photo electric sensor
(L) Pressure sensor
(M) Rotary encoder
(N) Stepping motor & Driver & Controller
(O) Graphic panel
(P) Field network device
(Q) Production stoppage models & replacement

BJ Series

Feature data

○ Polarized retroreflective type

● BJ3M-PDT / BJ3M-PDT-P

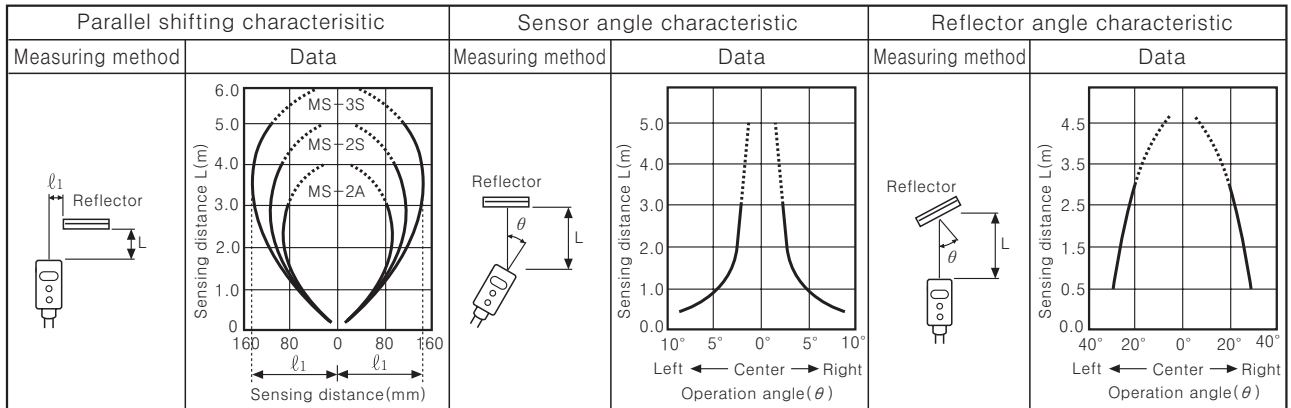

○ Diffuse reflective

● BJ1M-DDT / BJ1M-DDT-P

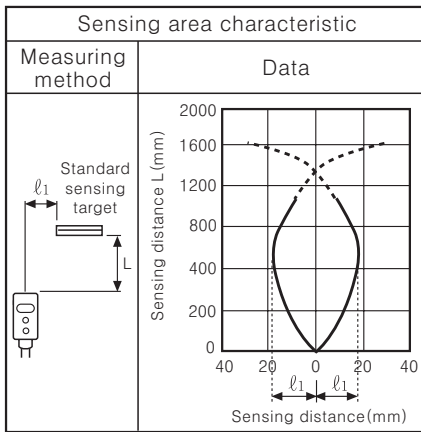

● BJ300-DDT / BJ300-DDT-P

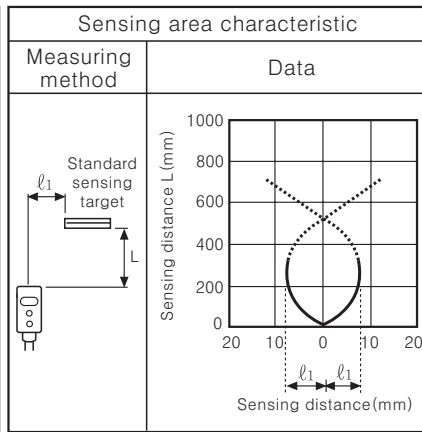

● BJ100-DDT / BJ100-DDT-P

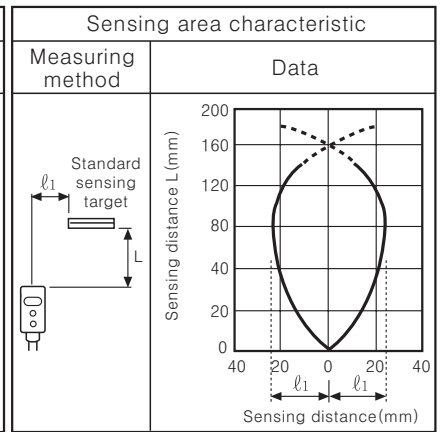

● BJG30-DDT

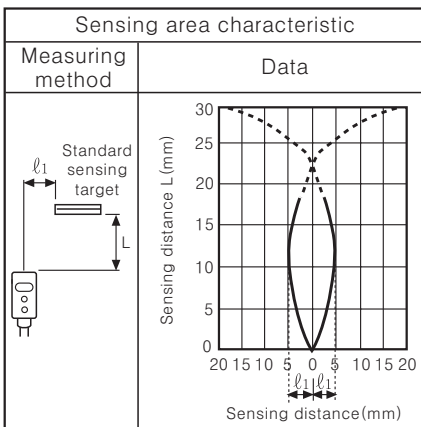

● BJN50-NDT / BJN50-NDT-P

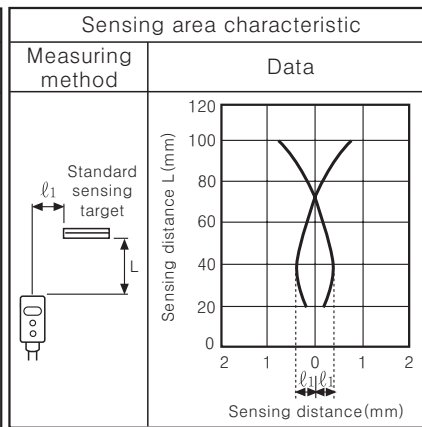

● BJN100-NDT / BJN100-NDT-P

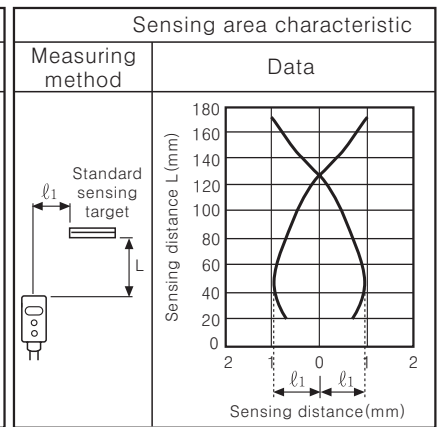

Connections

● Transmitted beam

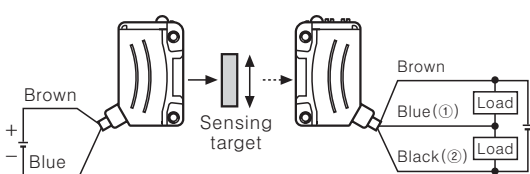

● Polarized retroreflective type

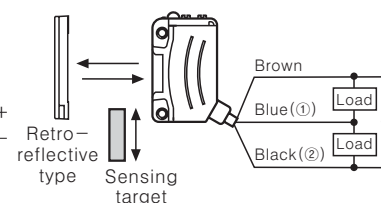

● Diffuse reflective

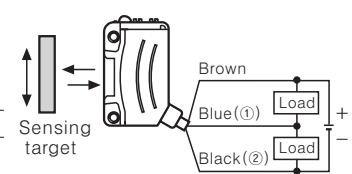

※ ① : The load connection of NPN open collector output, ② : The load connection of PNP open collector output

Long sensing distance/Micro spot type

Control output diagram

●NPN output

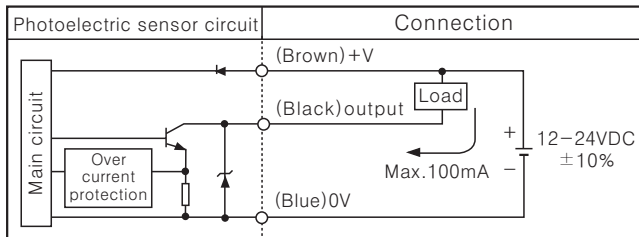

●PNP output

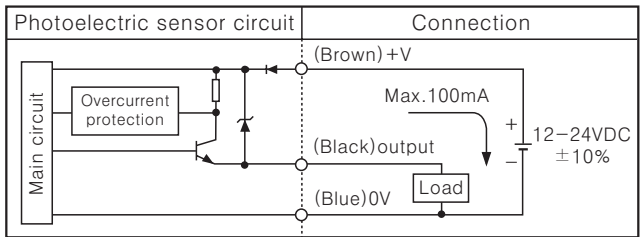

Operation mode

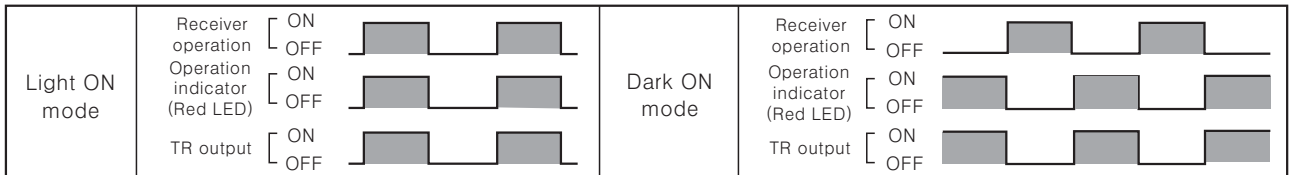

Dimensions

(Unit:mm)

●Transmitted beam type

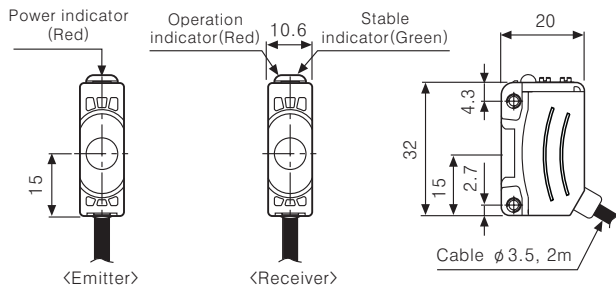

●Reflector (Include: MS-2A, Sold separately: MS-2S, MS-3S)

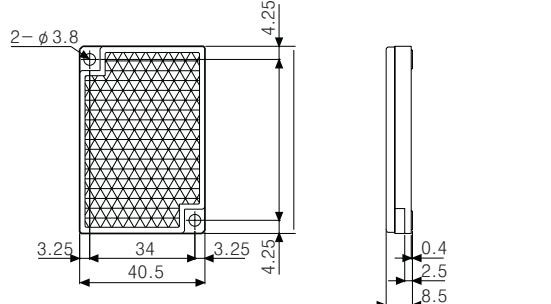

●Diffuse reflective type (Connect the bracket A)

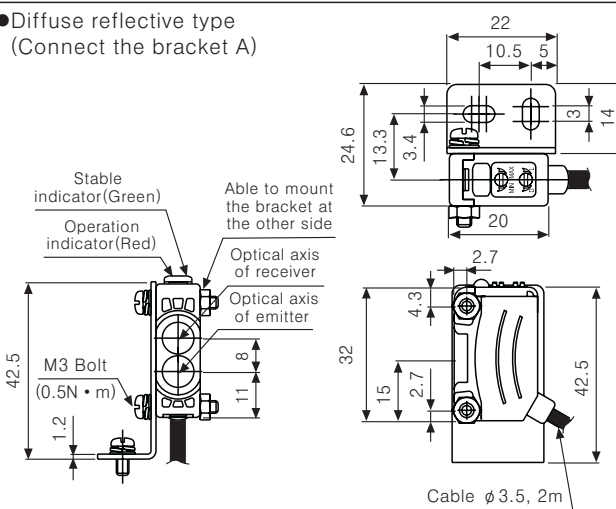

●Polarized retroreflective type (Connect the bracket B)

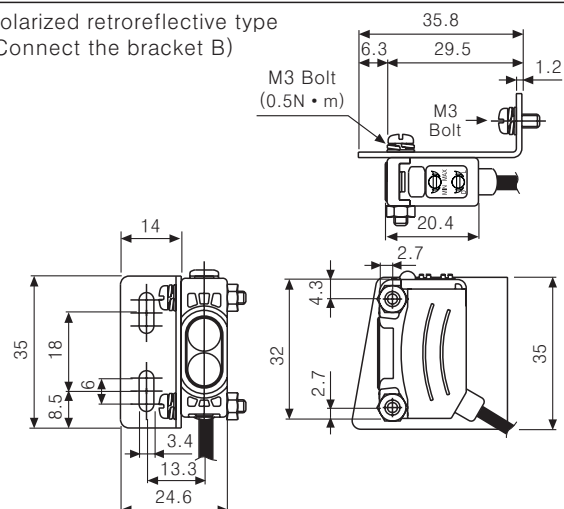

●Bracket A

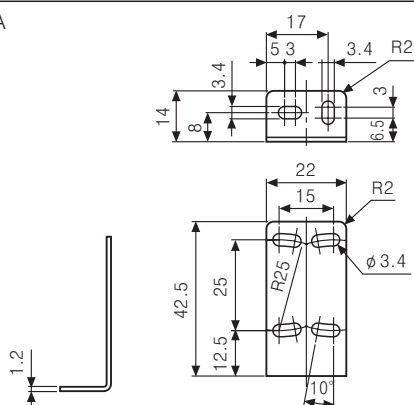

●Bracket B (Sold separately)

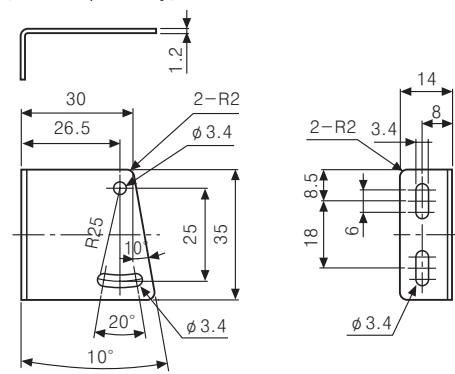

(A) Counter

(B) Timer

(C) Temp. controller

(D) Power controller

(E) Panel meter

(F) Tacho/Speed/Pulse meter

(G) Display unit

(H) Sensor controller

(I) Switching power supply

(J) Proximity sensor

(K) Photo electric sensor

(L) Pressure sensor

(M) Rotary encoder

(N) Stepping motor & Driver & Controller

(O) Graphic panel

(P) Field network device

(Q) Production stoppage models & replacement

BJ Series

Operation mode and Timing diagram

Emitter

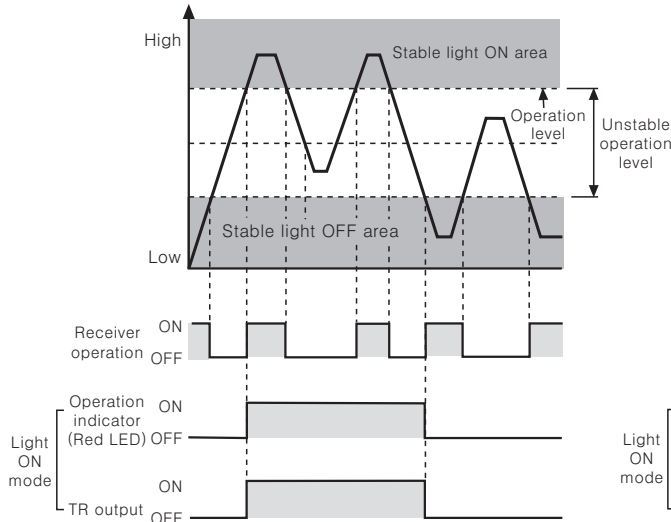

Diffuse reflective/Polarized retroreflective

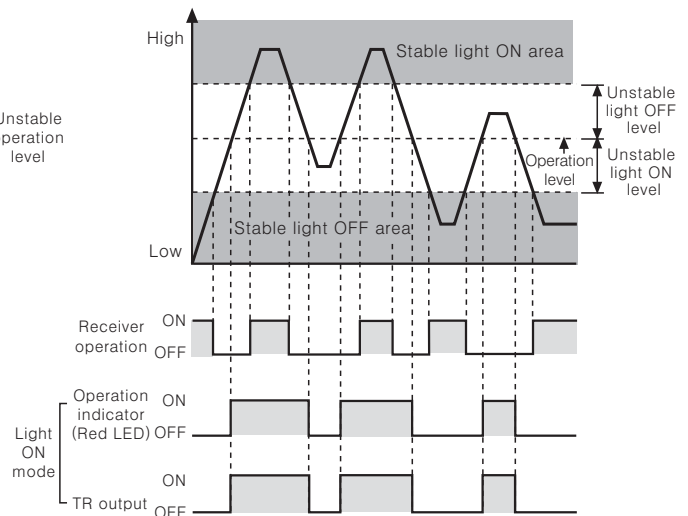

※ The waveform of 'Operation mode indicator' and 'TR output' is for Light ON mode, it is operated as reverse in Dark ON mode.

Mounting and sensitivity adjustment

For mounting

Please use screw M3 for mounting of sensor, set the tightening torque under 0.5 N • m.

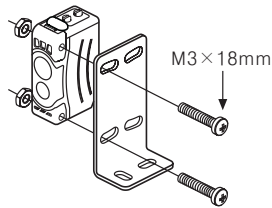

Switching of operation mode

Light ON mode (Light ON)		Turn the operation switching adjuster to right (L direction), it is set as Light ON mode.
Light OFF mode (Dark ON)		Turn the operation switching adjuster to left (D direction), it is set as Light OFF mode.

※ The operation switching adjuster is installed in the receiver for transmitted beam type.

Mounting

Transmitted beam type

- Place the emitter and receiver facing each other and apply the power.
- After adjust the position of the emitter and receiver and check their stable indicating range, mount them in the middle of the range.
- After mounting, check the operation of sensor and lighting of stable indicator in both status. (None or sensing target status)

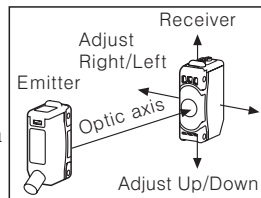

※ When the sensing target is translucent or small (Under ϕ 16mm), it can be missed by the sensor because the light can penetrate it.

Polarized retroreflective type

- Place the Sensor and retroreflective facing each other and apply the power.
- After adjust the position of the Sensor and retro-reflective and check their stable indicating range, mount them in the middle of the range.
- After mounting, check the operation of sensor and lighting of stable indicating in both status. (None or sensing target status)

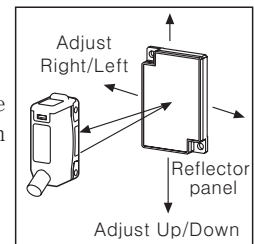

Diffuse reflective type

After place a sensing target, adjust the sensor to up • down, left • right. Then, fix the sensor in center of position where the indicator is operating.

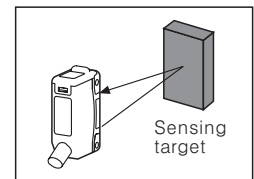

Object (Copper wire) detection <Micro spot type>

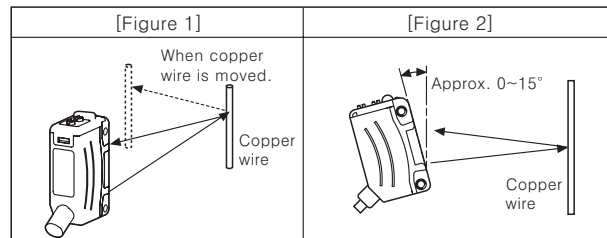



※ Mount sensor slanted at an angle ranged 0~15° shown above as [Figure 2] for stable detection to detect as shown in [Figure 1].

Long sensing distance/Micro spot type

■ Sensitivity adjustment

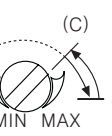
◎Sensitivity adjustment

Order	Position	Description
1	(A) 	Turn the sensitivity adjuster to the right of min. and check position(A) where the indicator is turned on in "Light ON status".
2	(A) (C) 	Turn the sensitivity adjuster more to the right of position(A), check position(B) where the indicator is turned on. And turn the adjuster to the left, check position(C) where the indicator is turned off in "Dark ON status". ※If the indicator is not lighted although the adjuster is turned to the max. position, the max. position is(C).
3	Optimal sensitivity (A) (C) 	Set the adjuster at the center of (A) and (C). To set the optimum sensitivity, check the operation and lighting of stable indicator with sensing target or without it. If the indicator is not lighted, please check the sensing method again because sensitivity is unstable.

※No sensitivity adjustment function available for BJJ30-DDT models

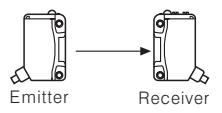
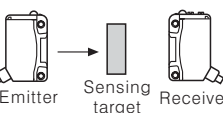
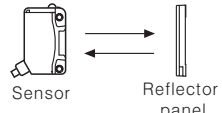
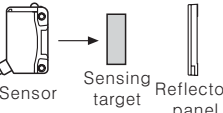
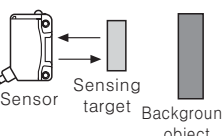
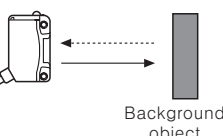
	"Light ON status"	"Light OFF status"
Transmitted beam type		
Polarized retro-reflective type		
Diffuse reflective		

※Set the sensitivity to operate in a stable light ON area, the reliability for the environment (Temperature, voltage, dust etc) will be increased.

※Do not apply an excessive force on adjuster, it can be broken.

(A)
Counter

(B)
Timer

(C)
Temp.
controller

(D)
Power
controller

(E)
Panel
meter

(F)
Tacho/
Speed/
Pulse
meter

(G)
Display
unit

(H)
Sensor
controller

(I)
Switching
power
supply

(J)
Proximity
sensor

(K)
Photo
electric
sensor

(L)
Pressure
sensor

(M)
Rotary
encoder

(N)
Stepping
motor &
Driver &
Controller

(O)
Graphic
panel

(P)
Field
network
device

(Q)
Production
stoppage
models &
replacement