

BEN Series

Compact, universal voltage type with built-in amplifier

■ Features

- Small and universal voltage type.
- Easy installation with LED indicators on product.
- Able to set the operation mode by switch.
(Light ON/Dark ON)
- Status and output LED indication
- Built-in IC photo diode for ambient light and electrical noise.



! Please read "Caution for your safety" in operation manual before using.



*MS-4 is sold separately.

■ Specifications

● AC/DC power, Relay contact output

Model	BEN10M-TFR	BEN5M-MFR	BEN3M-PFR	BEN300-DFR
Sensing type	Transmitted beam	Retroreflective (Standard type)	Retroreflective (with polarizing filter)	Diffuse reflective
Sensing distance	10m	(*1) 0.1 ~ 5m	(*1) 0.1 ~ 3m	(*2) 300mm
Sensin target	Opaque materials of Min. ϕ 16mm	Opaque materials of Min. ϕ 60mm		Transparent, Translucent, Opaque materials
Hysteresis	—————			Max. 20% at rated setting distance
Response time	Max. 20ms			
Power supply	24-240VAC \pm 10% 50/60Hz, 24-240VDC \pm 10% (Ripple P-P:Max. 10%)			
Power consumption	Max. 4VA			
Light source	Infrared LED(modulated)		Red LED (Modulated : 660nm)	Infrared LED(modulated)
Sensitivity adjustment	—————	Adjuster		
Operation mode	Light ON / Dark ON mode selectable			
Control output	Relay contact output (Contact capacity : 30VDC 3A resistive load, 250VAC 3A resistive load, Relay contact composition : 1c)			
Relay life cycle	Mechanically : Min. 50,000,000, Electrically : Min. 100,000			
Light receiving element	Built-in IC type photo diode			
Indicator	Operation indicator : Orange, Stable indicator : Green (The orange lamp on Emitter of transmitted beam type is for power indication)			
Connection	Outgoing cable			
Insulation resistance	Min. 20M Ω (at 500VDC mega)			
Noise strength	\pm 1,000V the square wave noise (pulse width:1 μ s) by the noise simulator			
Dielectric strength	1000VAC 50/60Hz for 1minute			
Vibration	Mechanical	1.5mm amplitude at frequency of 10 ~ 55Hz in each of X, Y, Z directions for 2 hours		
	Malfuction	1.5mm amplitude at frequency of 10 ~ 55Hz in each of X, Y, Z directions for 10 minutes		
Shock	Mechanical	500m/s ² (50G) in X, Y, Z directions for 3 times		
	Malfuction	100m/s ² (10G) in X, Y, Z directions for 3 times		
Ambient illumination	Sunlight : Max. 11,000lx, Incandescent lamp : Max. 3,000lx			
Ambient temperature	-20 ~ +65 $^{\circ}$ C (at non-freezing status), Storage:-25 ~ +70 $^{\circ}$ C			
Ambient humidity	35 ~ 85%RH, Storage : 35 ~ 85%RH			
Material	Case : ABS, Lens cover : Acrylic, Lens : Acrylic			
Protection	IP50 (IEC standard)			
Cable	ϕ 6.0mm, 5P, Length : 2m			
Accessory	Individual	—————	Reflector (MS-2), Adjustment driver	Adjustment driver
	Common	Fixing bracket, Bolts, Nuts		
Unit weight	Approx. 354g	Approx. 208g		Approx. 195g

*(*1) It is mounting distance between sensor and reflector MS-2 and it is same when MS-4 is used. It is detectable under 0.1m.

*(*2) It is for Non-glossy white paper (100 \times 100mm).

Universal Voltage Type with Built-in Amplifier

●DC power, Solid state output

Model	BEN10M-TDT	BEN5M-MDT	BEN3M-PDT	BEN300-DDT
Sensing type	Transmitted beam	Retroreflective	Retroreflective (with polarizing filter)	Diffuse reflective
Sensing distance	10m	(★1) 0.1 ~ 5m	(★1) 0.1 ~ 3m	(★2) 300mm
Sensing target	Opaque materials of Min. ϕ 16mm	Opaque materials of Min. ϕ 60mm		Transparent, Translucent, Opaque materials
Hysteresis	_____			Max. 20% at sensing distance
Response time	Max. 1ms			
Power supply	12-24VDC \pm 10% (Ripple P-P : Max. 10%)			
Current consumption	Max. 40mA			
Light source	Infrared LED(modulated)		Red LED (modulated, 660nm)	Infrared LED(modulated)
Sensitivity adjustment	_____		Adjuster	
Operation mode	Light ON / Dark ON mode selectable			
Control output	●NPN/PNP output simultaneously • PNP open collector output \Rightarrow Load voltage:Max. 30VDC, Load current:Max. 200mA, Residual voltage:Max. 1V • NPN open collector output \Rightarrow Output voltage:Min. (Power supply-2.5)VDC, Load current:Max. 200mA			
Protection circuit	Reverse polarity protection, Short-circuit protection			
Light receiving element	Built-in IC type photo diode			
Indicator	Operation indicator : Orange, Stable indicator : Green (The orange lamp on Emitter of transmitted beam type is for power indicator)			
Connection	Outgoing cable			
Insulation resistance	Min. 20M Ω (at 500VDC mega)			
Noise strength	\pm 240V the square wave noise (pulse width:1 μ s) by the noise simulator			
Dielectric strength	1000VAC 50/60Hz for 1minute			
Vibration	1.5mm amplitude at frequency of 10 ~ 55Hz in each of X, Y, Z directions for 2 hours			
Shock	500m/s ² (50G) in X, Y, Z directions for 3 times			
Ambient illumination	Sunlight : Max. 11,000lx, Incandescent lamp : Max. 3,000lx			
Ambient temperature	-20 ~ +55 $^{\circ}$ C (at non-freezing status), Storage : -25 ~ +70 $^{\circ}$ C			
Ambient humidity	35 ~ 85%RH, Storage : 35 ~ 85%RH			
Protection	IP50(IEC standard)			
Material	Case : ABS, Lens cover : Acrylic, Lens : Acrylic			
Cable	ϕ 6.0mm, 4P, Length : 2m			
Accessory	Individual	_____	Reflector (MS-2), Adjustment driver	Adjustment driver
	Common	Fixing bracket, Bolts, Nuts		
Approval	CE			
Unit weight	Approx. 342g	Approx. 200g		Approx. 187g

※(★1)It is mounting distance between sensor and reflector MS-2 and it is same when MS-4 is used. It is detectable under 0.1m.
 ※(★2)It is for Non-glossy white paper(100 \times 100mm).

■ Feature data

○ Transmitted beam

● BEN10M-TFR ● BEN10M-TDT

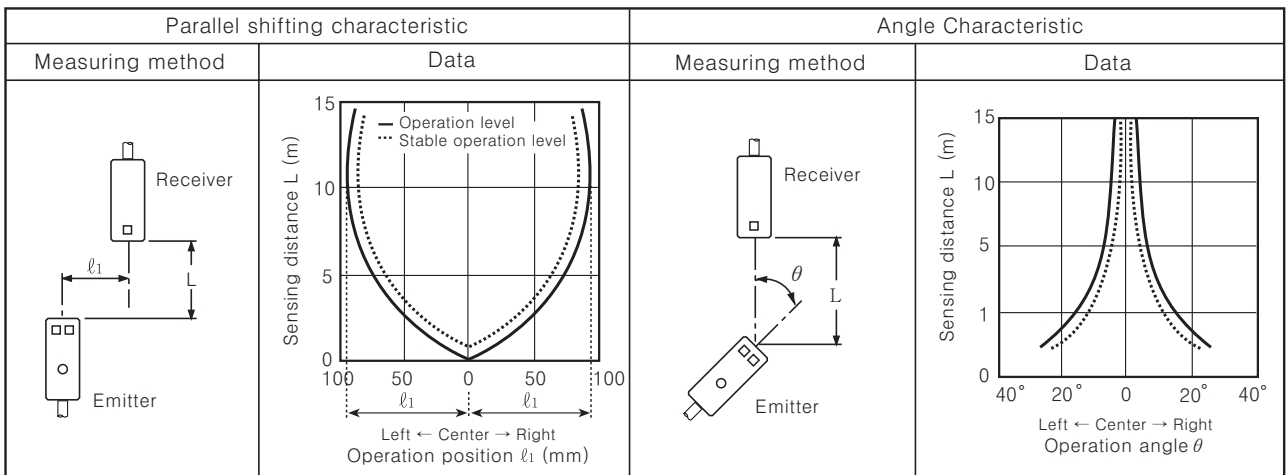

- (A) Counter
- (B) Timer
- (C) Temp. controller
- (D) Power controller
- (E) Panel meter
- (F) Tacho/Speed/Pulse meter
- (G) Display unit
- (H) Sensor controller
- (I) Switching power supply
- (J) Proximity sensor
- (K) Photo electric sensor
- (L) Pressure sensor
- (M) Rotary encoder
- (N) Stepping motor & Driver & Controller
- (O) Graphic panel
- (P) Production stoppage models & replacement

BEN Series

Feature data

Retroreflective

●BEN5M-MFR ●BEN5M-MDT

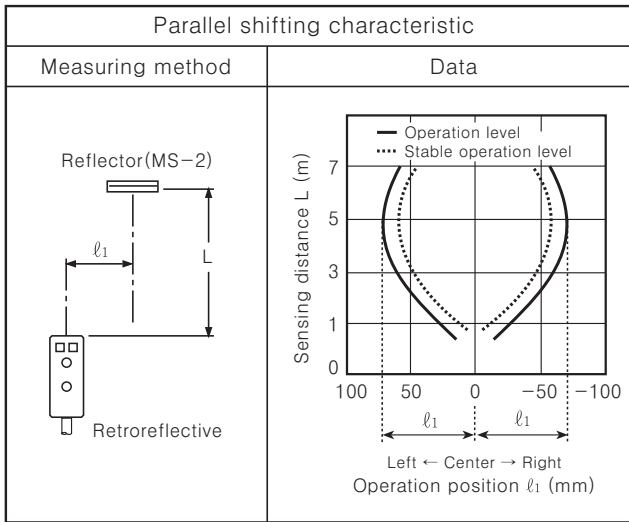

Polarized retroreflective

●BEN3M-PFR ●BEN3M-PDT

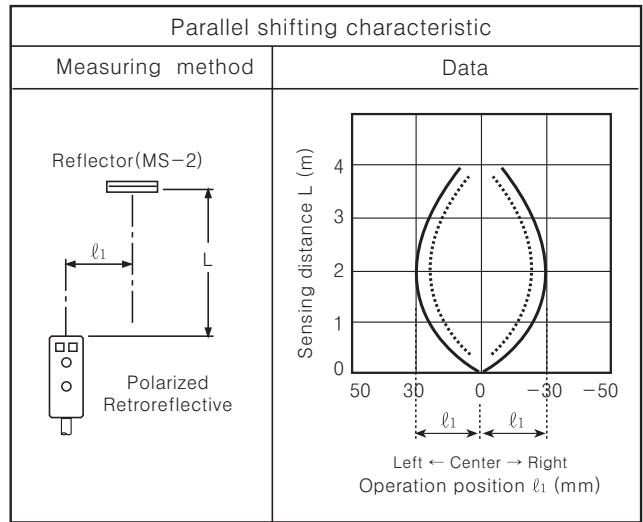

●BEN5M-MFR ●BEN5M-MDT

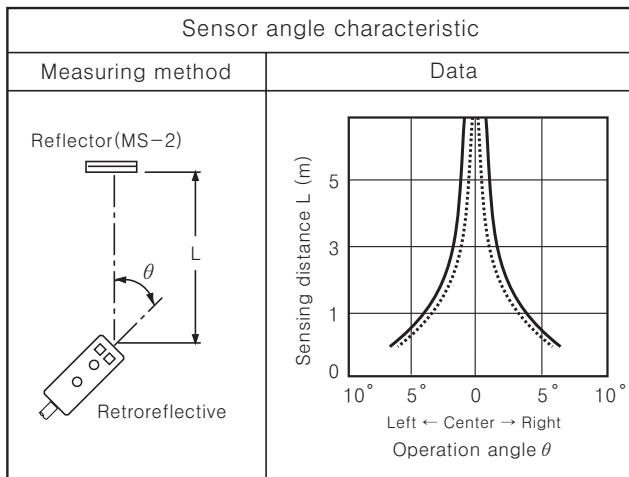

●BEN3M-PFR ●BEN3M-PDT

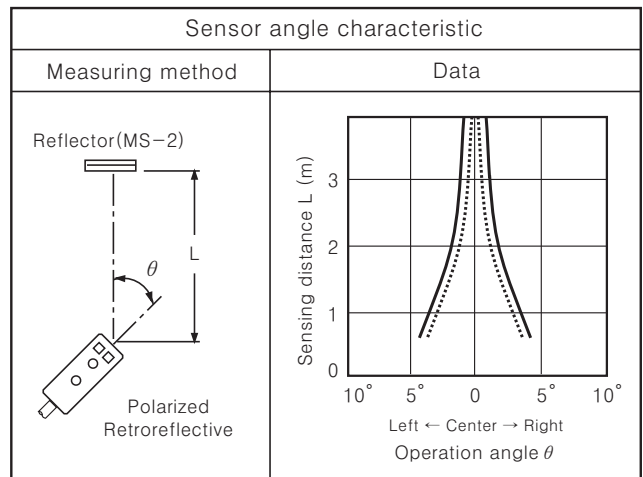

●BEN5M-MFR ●BEN5M-MDT

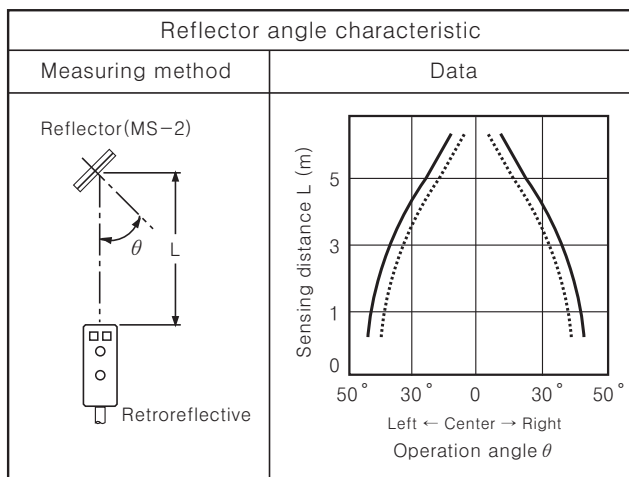

●BEN3M-PFR ●BEN3M-PDT

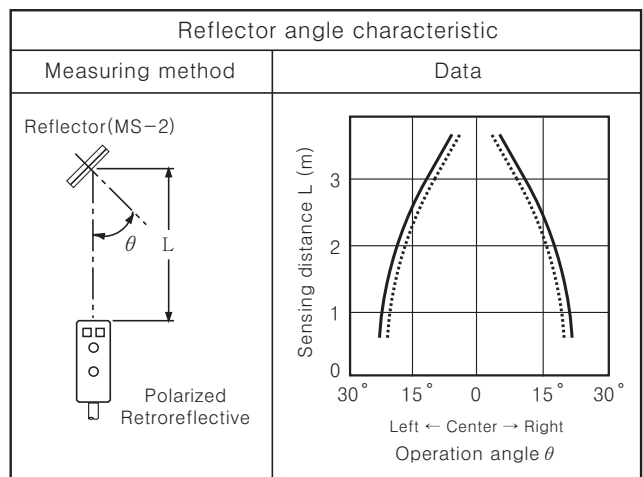

Universal Voltage Type with Built-in Amplifier

Feature data

● Diffuse reflective

● BEN300-DFR ● BEN300-DDT

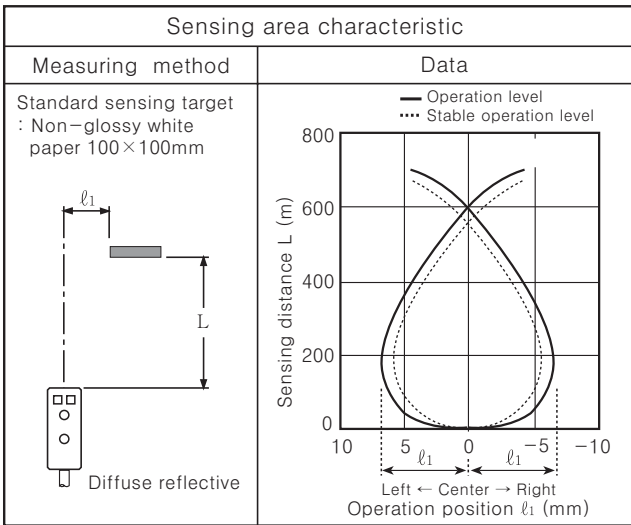

Operation mode

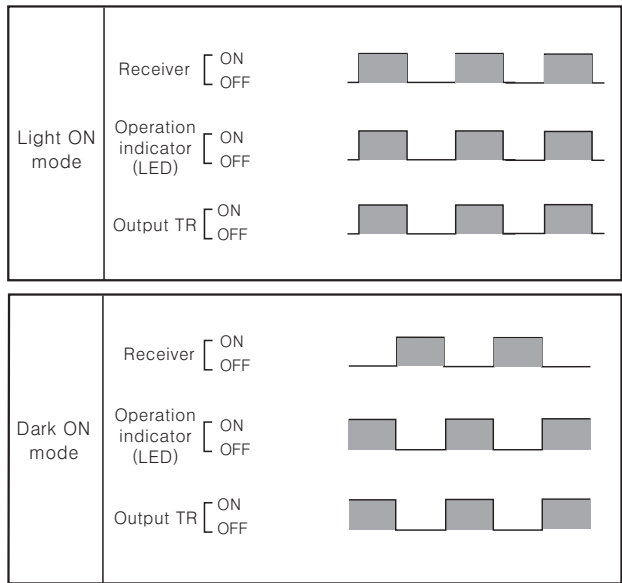

Control output diagram

● DC voltage (NPN/PNP synchronous output)

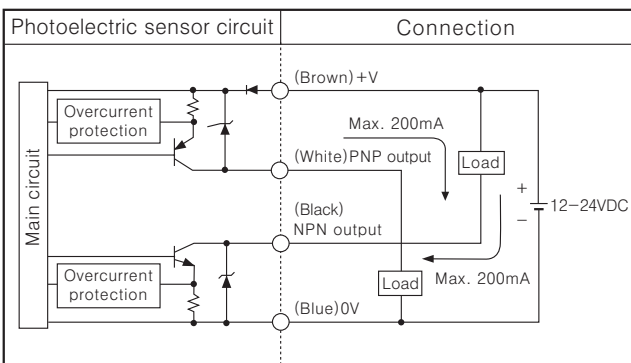

● Universal voltage (Relay contact output)

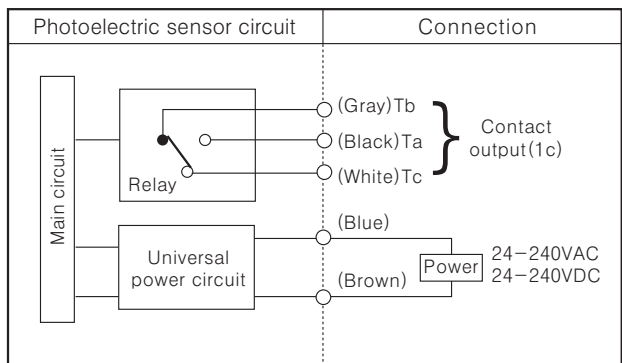

※ In case of product with the output protection device, if terminals of control output are short circuited or overcurrent condition is existed, the control output will turn off due to protection circuit.

Operation mode and timing chart

● Light ON mode

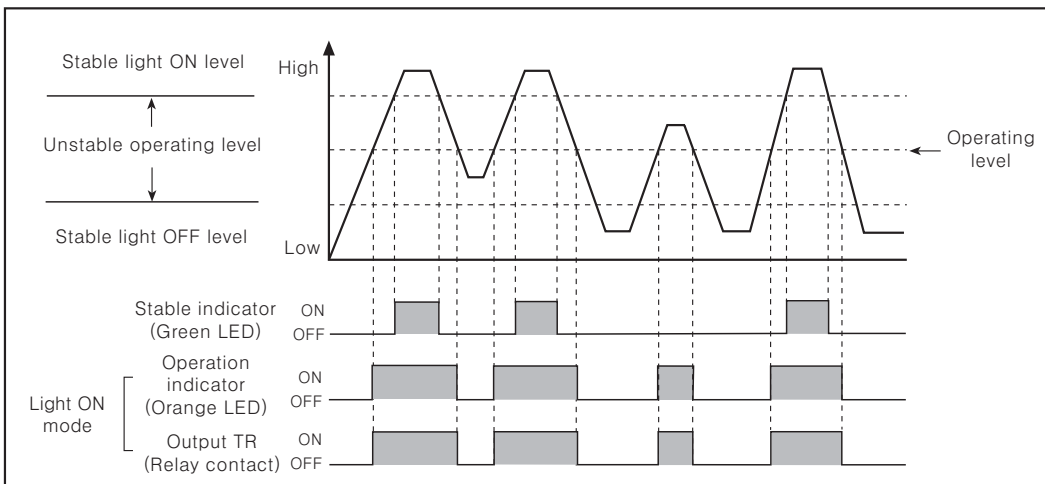

※ The waveform of output TR and operation indicator are the state of operation for Light ON mode, but in case of Dark ON mode, it operates as reverse against Light ON mode.

(A) Counter

(B) Timer

(C) Temp. controller

(D) Power controller

(E) Panel meter

(F) Tacho/Speed/Pulse meter

(G) Display unit

(H) Sensor controller

(I) Switching power supply

(J) Proximity sensor

(K) Photo electric sensor

(L) Pressure sensor

(M) Rotary encoder

(N) Stepping motor & Driver & Controller

(O) Graphic panel

(P) Production stoppage models & replacement

BEN Series

Connections

Transmitted beam		Retroreflective	Diffuse reflective
<p>●BEN10M-TFR1</p>	<p>●BEN10M-TFR2</p>	<p>●BEN5M-MFR/BEN3M-PFR (with polarizing filter)</p>	<p>●BEN300-DFR</p>
<p>●BEN10M-TDT1</p>	<p>●BEN10M-TDT2</p>	<p>●BEN5M-MDT/BEN3M-PDT (with polarizing filter)</p>	<p>●BEN300-DDT</p>

※ Unused line must be insulated.

Dimensions

(Unit:mm)

Product

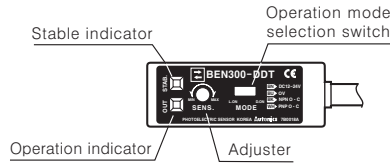

- Transmitted beam
- Retroreflective
- Diffuse reflective

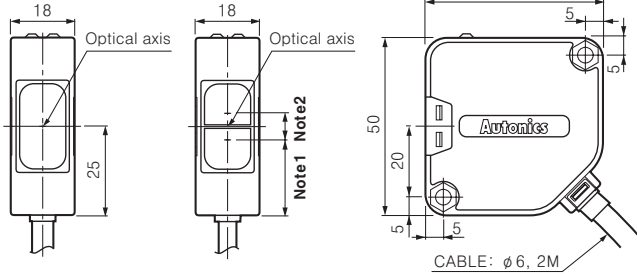

※ Note1) Retroreflective : 21.25mm, Diffuse reflective : 20.25mm
 Note2) Retroreflective : 7.5mm, Diffuse reflective : 9.5mm

Bracket

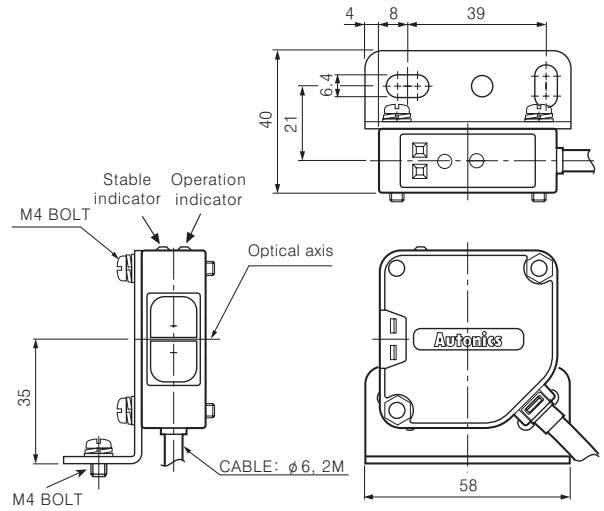

Reflector

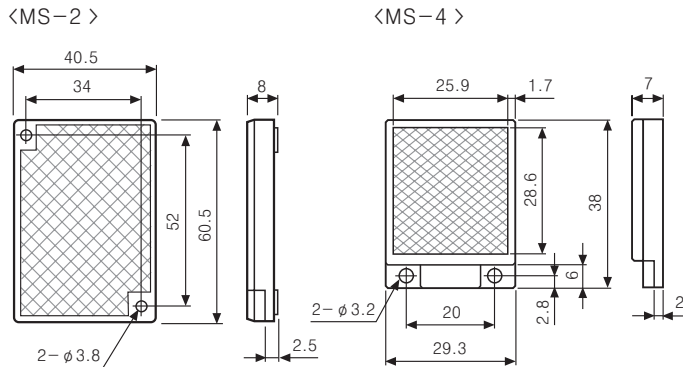

Bracket

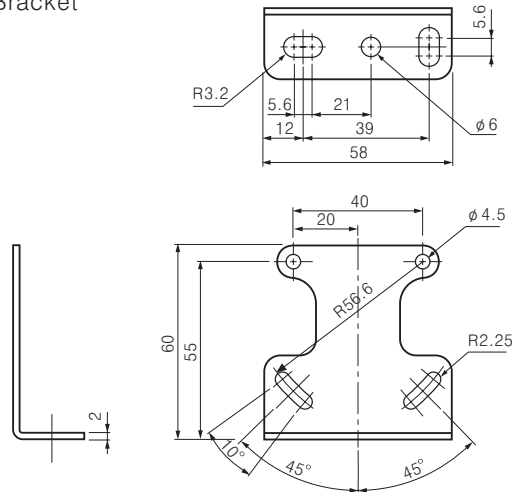

Universal Voltage Type with Built-in Amplifier

■ Mounting and sensitivity adjustment

◎ Transmitted beam type

1. Supply the power to the photoelectric sensor, after set the emitter and the receiver facing each other.
 2. Set the receiver in the middle of the operation range of indicator adjusting the receiver or the emitter right and left, up and down.
 3. Adjust up and down direction as the same.
 4. After adjustment, check the stability of operation putting the object at the optical axis.
- ※ If the sensing target is translucent body or smaller than $\phi 16\text{mm}$, it can be missed by sensor cause light passed.

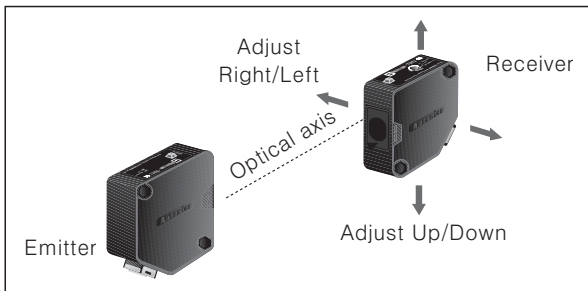

◎ Diffuse reflective type

1. Adjust sensitivity regarding the effectiveness of behind object or mounting side.
 2. Set the target at a position to be detected by the beam, then turn the adjuster until position ① in the middle of the operation range of indicator from min. position of the adjuster.
 3. Take the target out of the sensing area, then turn the adjuster until position ② where the indicator turns on. If the indicator does not turn on, Max. position is position ②.
 4. Set the adjuster at the middle of two switching position ①, ②.
- ※ The sensing distance indicated on specification chart is against $100 \times 100\text{mm}$ of non-glossy white paper. Be sure that it can be different by size, surface and gloss of target.

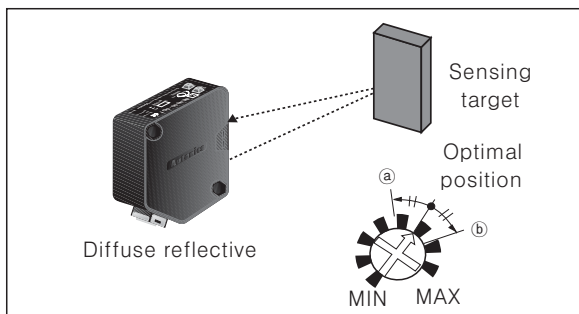

◎ Retroreflective type

1. Supply the power, after set the photoelectric sensor and the reflector (MS-2) facing each other.
2. Set the Photoelectric sensor in the middle of the position in the middle of the operation range of indicator adjusting the reflector or the sensor right and left, up and down.

3. Adjust up and down direction as the same.

4. After adjustment, check the stability of operation putting the object at the optical axis.

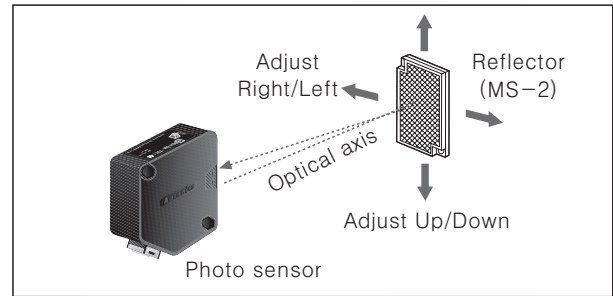

※ If use more than 2 photoelectric sensors in parallel, the space between them should be more than 30cm.

※ If reflectance of target is higher than non-glossy white paper, it might cause malfunction by reflection from the target when the target is near to photoelectric sensor. Therefore put enough space between the target and photoelectric sensor or the surface of target should be installed at an angle of $30^\circ \sim 45^\circ$ against optical axis. (When detecting target with high reflectance near by, photoelectric sensing with the polarizing filter should be used.)

※ Sensitivity adjustment : Please see the diffuse reflective type.

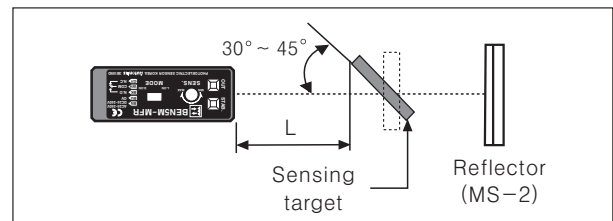

※ If the mounting place is too small, please use MS-4 instead of MS-2 for same sensing distance.



◎ Retroreflective type (With polarizing filter)

The light passed through the polarizing filter of emitter reaches to MS-2 converting as horizontal direction, it reaches to photodetector through the filter of receiver converting as vertical by MS-2 function. Even it can detect normal mirror.

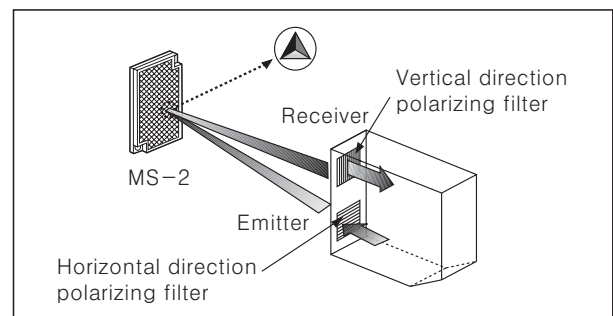

(A) Counter

(B) Timer

(C) Temp. controller

(D) Power controller

(E) Panel meter

(F) Tacho/Speed/Pulse meter

(G) Display unit

(H) Sensor controller

(I) Switching power supply

(J) Proximity sensor

(K) Photo electric sensor

(L) Pressure sensor

(M) Rotary encoder

(N) Stepping motor & Driver & Controller

(O) Graphic panel

(P) Production stoppage models & replacement