

## Flat type proximity sensor

### ■ Features

- Easy to mount in narrow space by Flat structure (Height: 10mm)
- Improved the noise resistance with dedicated IC (DC)
- Reverse power polarity, surge, overcurrent protection
- Red LED status indication
- IP67 rated waterproof structure (IEC standard)
- Replacer for micro switches and limit switches



**⚠ Please read "Caution for your safety" in operation manual before using.**



### ■ Type

#### ○ DC 3-wire type

Appearance	Model
	PFI25-8DN
	PFI25-8DP
	PFI25-8DN2 ※
	PFI25-8DP2 ※

▶ "※" mark can be customized.

#### ○ AC 3-wire type

Appearance	Model
	PFI25-8AO
	PFI25-8AC

### ■ Specification

Model	PFI25-8DN PFI25-8DP PFI25-8DN2 PFI25-8DP2	PFI25-8AO PFI25-8AC
Sensing distance	8mm ±10%	
Hysteresis	Max. 10% of sensing distance	
Standard sensing target	25×25×1mm (Iron)	
Setting distance	0 ~ 5.6mm	
Power supply (Operating voltage)	12-24VDC (10-30VDC)	100-240VDC (85-264VAC)
Current/Leakage consumption	Max. 10mA	Max. 2.5mA
Response frequency(*1)	200Hz	20Hz
Residual voltage	Max. 1.5V	Max. 10V
Affection by Temp.	±10% Max. for sensing distance at +20°C within temperature range of -25 ~ +70°C	
Control output	Max. 200mA	Max. 150mA
Insulation resistance	Min. 50MΩ (at 500VDC mega)	
Dielectric strength	1500VAC 50/60Hz for 1 minute	2500VAC 50/60Hz for 1 minute
Vibration	1mm amplitude at frequency of 10 ~ 55Hz in each of X, Y, Z directions for 2 hours	
Shock	500m/s <sup>2</sup> (50G) in X, Y, Z direction for 3 times	
Indicator	Operation indicator (Red LED)	
Ambient temperature	-25 ~ +70°C (at non-freezing status)	
Storage temperature	-30 ~ +80°C (at non-freezing status)	
Ambient humidity	35 ~ 95%RH	
Protection circuit	Surge, Reverse power polarity, Overcurrent protection circuit	Surge protection circuit
Cable	∅4×3P, 2m	∅4×2P, 2m
Protection	IP67 (IEC standard)	
Approval		
Unit weight	Approx. 80g	

※ (\*1) The response frequency is the average value. The standard sensing target is used and the width is set as 2 times of the standard sensing target, 1/2 of the sensing distance for the distance.

(A) Counter

(B) Timer

(C) Temp. controller

(D) Power controller

(E) Panel meter

(F) Tacho/Speed/Pulse meter

(G) Display unit

(H) Sensor controller

(I) Switching power supply

(J) Proximity sensor

(K) Photo electric sensor

(L) Pressure sensor

(M) Rotary encoder

(N) Stepping motor & Driver & Controller

(O) Graphic panel

(P) Production stoppage models & replacement

# PFI Series

## Dimensions

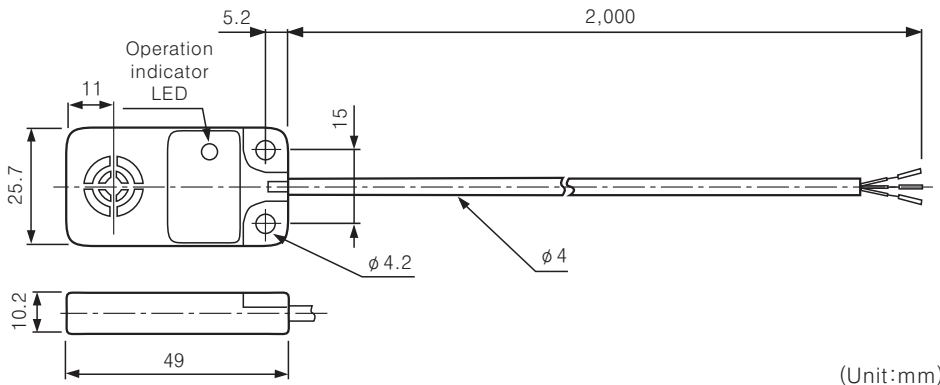

## Control output diagram

### DC 3-wire type

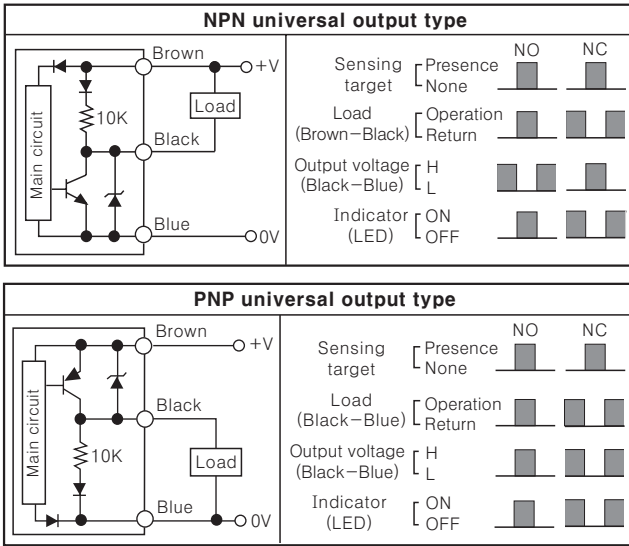

### AC 2-wire type

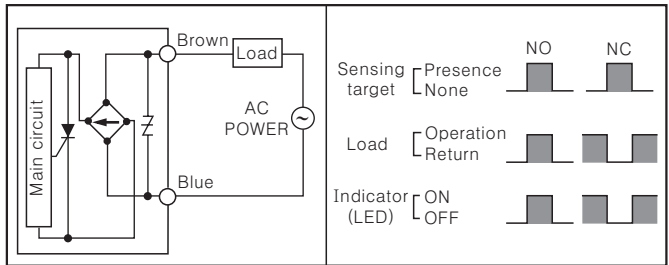

## Proper usage

### Mutual-interference

When several proximity sensors are mounted closely, sensors may cause a malfunction due to mutual interference. Therefore, be sure to provide a minimum distance between the two sensors, as below chart.

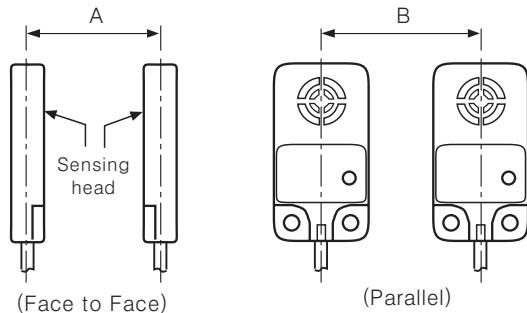

A	100
B	80

(Unit:mm)

### Influence by surrounding metals

When sensors are mounted on metallic panel, it may cause malfunction affected by any metallic object except target. Therefore, be sure to provide a minimum as below chart.

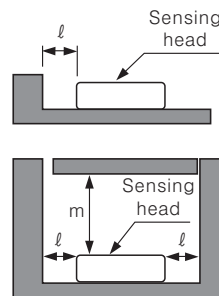

When the height between the proximity sensor and surrounding metals is same.

When the height between the proximity sensor and surrounding metals is different.

l	5
m	15

(Unit:mm)