

W75 × H25mm Digital graphic panel meter for mosaic panel

■ Features

- Various input function
: 0–2VDC, 0–10VDC, 1–5VDC,
DC0–1mA, DC4–20mA
- Prescale function (High/Low scale setting)
- Max. display : –999 ~ 9999
- Error display function or self diagnosis function
- High quality by Microprocessor built-in
- Display accuracy : $F \cdot S \pm 0.2\% \text{ rdg} \pm 1 \text{ digit}$



⚠ Please read "Caution for your safety" in operation manual before using.

■ Ordering information

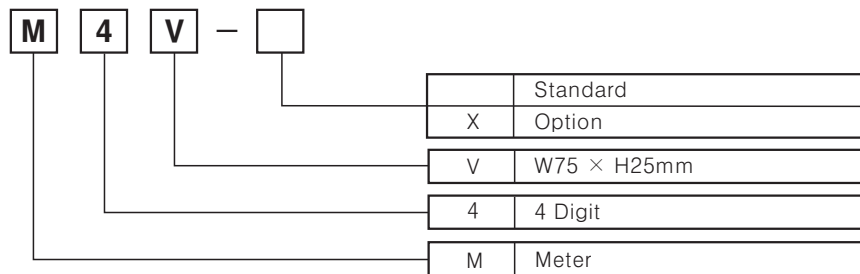

※It is enable to customized with another specifications except for standard one.

■ Specifications

Model		M4V
Measurement function		DV Volt, DC Ampere, DC4–20mA, 1–5VDC
Power supply		12–24VDC
Allowable voltage range		90 ~ 110% of rated voltage
Power consumption		Approx. less than 2W
Display method		7 Segment red LED display (Segment height 14mm)
Display accuracy		0 ~ 50°C : $F \cdot S \pm 0.2\%$, –10 ~ 0°C : $F \cdot S \pm 0.3\%$ (rdg ± 1 digit)
Sampling period		0.5 sec.
Setting method		Scale set by front switches
Max. allowable input		150% of measurement input
Set-diagnosis		Error indication
Insulation resistance		Min. 100M Ω (at 500VDC mega)
Dielectric strength		2000VAC 50/60Hz for 1 minute
Noise strength		± 300 V the square wave noise (pulse width:1 μ s) by the noise simulator
Vibration	Mecanical	0.75mm amplitude at frequency of 10 ~ 50Hz in each of X, Y, Z directions for 1hour
	Malfunction	0.5mm amplitude at frequency of 10 ~ 50Hz in each of X, Y, Z directions for 10minutes
Shock	Mecanical	300m/s ² (30G) in X, Y, Z direction for 3 times
	Malfunction	100m/s ² (10G) in X, Y, Z directions for 3 times
Ambient temperature		–10 ~ +50°C (at non-freezing status)
Storage temperature		–20 ~ +60°C (at non-freezing status)
Ambient humidity		35 to 85%RH
Unit weight		Approx. 83g

Graphic Panel Meter

Dimensions

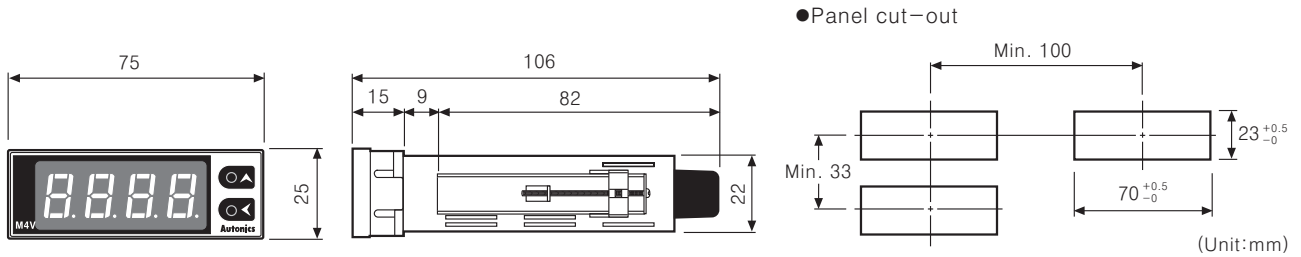

※It is attached on mosaic graphic panel. Please mount the unit properly on general panel.

Input and connection

Input	Display	Connection
0-2VDC	0-2U	0-2VDC, 1-5VDC, 0-10VDC SOURCE HI ↓ LOW ↓ - + [1] [2] [3] [4] [5] [6]
1-5VDC	1-5U	
0-10VDC	0-10	
DC0-1mA	InR	DC0-1mA SOURCE HI ↓ LOW ↓ - + [1] [2] [3] [4] [5] [6]
DC4-20mA	4-20	DC4-20mA SOURCE HI ↓ LOW ↓ - + [1] [2] [3] [4] [5] [6]

Factory default setting

In-t	0-2U	dot	0.0
L-SC	0.0	In-b	00
H-SC	100.0	LoC	oFF

Error display

Display indicates "Error" when wrong measuring input value is applied.

Display an Error

- In case of lower value than measuring input value.

Ex) In case of applying DC2mA when measuring input range is selected as DC4-20mA : "LLLL" flashes.

- In case of higher value than measuring input value.

Ex) In case of applying DC22mA when measuring input range is selected as DC4-20mA : "HHHH" flashes.

- In case of damaging the memory chip by high frequency noise, strong surge noise : "Er-E" flashes.

Cancellation of Error

- "HHHH" and "LLLL" ERROR is to exceed measuring input range, therefore if measuring input value is applied within input range, ERROR message will be cleared automatically.

- "oUEr" is indicated by mis-connection or in case of occurring something wrong in measuring input.

Please cut off the power and then check measuring input.

- "Er-E" indicates data damage programmed in memory chip, and damaged data can not be recovered.

Ask a dealer shop for A/S.

It is impossible to clear "Er-E" by end-user, therefore it must be repaired by our engineer.

(A) Counter

(B) Timer

(C) Temp. controller

(D) Power controller

(E) Panel meter

(F) Tacho/Speed/Pulse meter

(G) Display unit

(H) Sensor controller

(I) Switching power supply

(J) Proximity sensor

(K) Photo electric sensor

(L) Pressure sensor

(M) Rotary encoder

(N) Stepping motor & Driver & Controller

(O) Graphic panel

(P) Production stoppage models & replacement

Parameter description

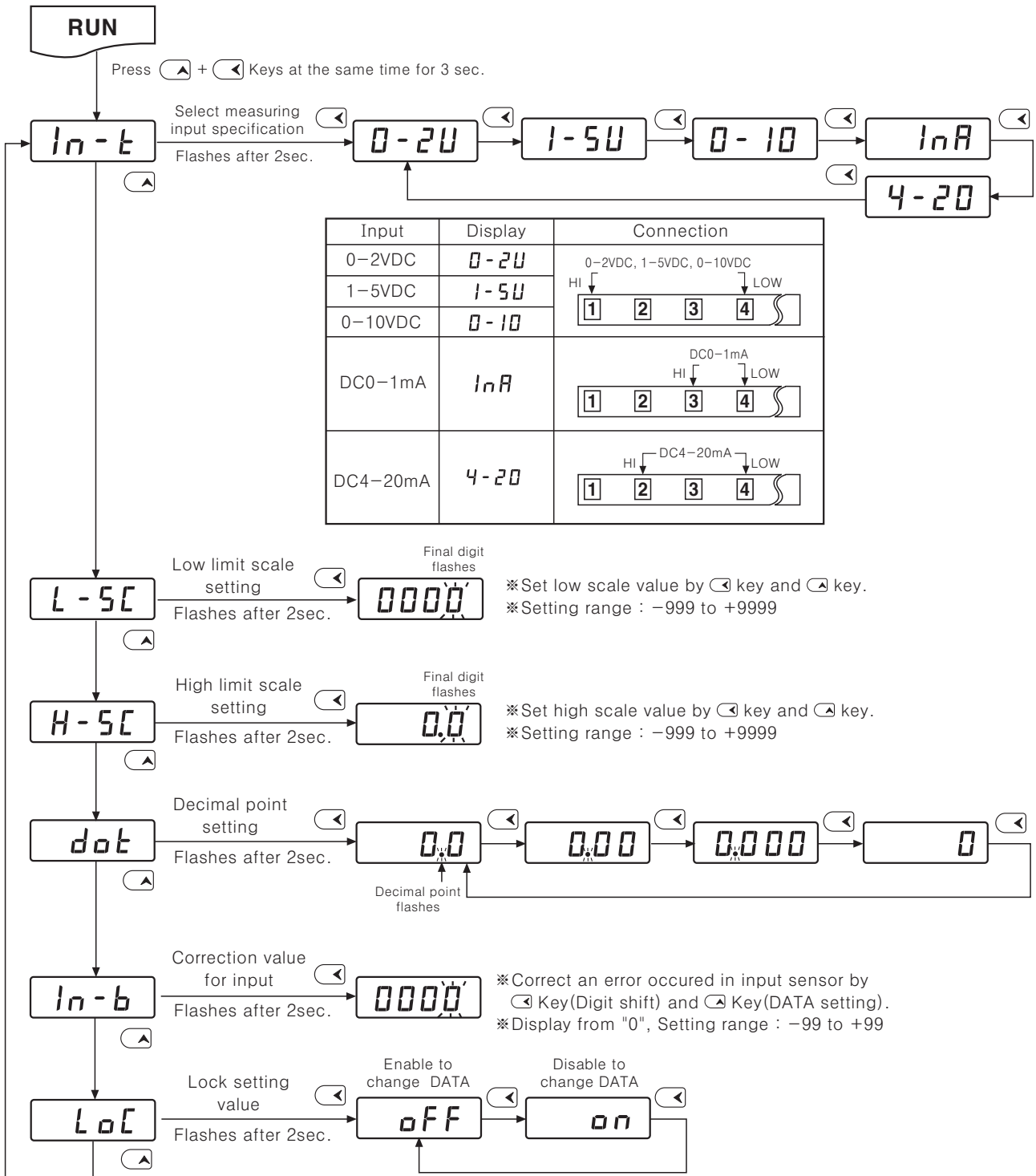

How to change the setting value

1. When advance to MODE, change digit flashing by Key then set DATA value by Key.
2. After complete DATA value setting, please press Key for 2sec. then it will move to next MODE saving DATA.
3. Press Key for 2sec. to return RUN mode after changing(Setting) DATA value in each MODE.

*Press Key for 2sec., then it will return to RUN without change setting value.

*When checking the setting value only in each mode. Press Key for 2sec., then press for 2sec. again.
(If press continuously, it will not advance to next mode and return to RUN mode)

*If any key is untouched for 60sec., it will return to RUN mode.

Graphic Panel Meter

■ Prescale function

This function is to display setting of particular High/Low-limit value in order to display High/Low-limit value of measuring input.

If measuring inputs are a or b and display values are A or B, it will display a=A, b=B as below graph.

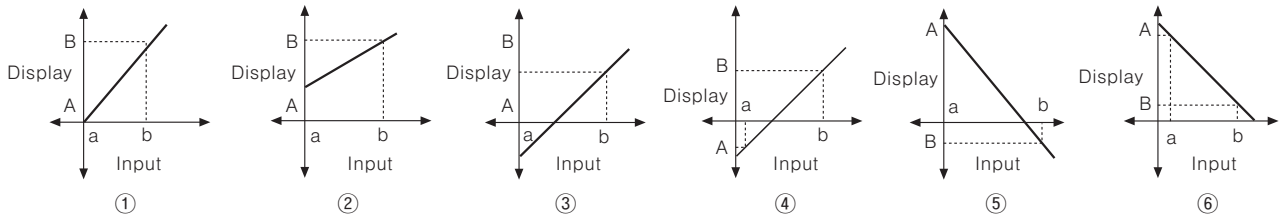

Ex) Able to set the display value for input as certain value (Not "0") by using prescale function.

Measuring input□	Prescale setting value	Display	Graph
0-10VDC	L-Scale : 0 H-Scale : 200	0 ~ 200	①
	L-Scale : 50 H-Scale : 200	50 ~ 200	②
	L-Scale : -100 H-Scale : 200	-100 ~ 200	③
	L-Scale : 200 H-Scale : -50	200 ~ -50	⑤

*Prescale value setting range → L-SC(Low limit) : -999 ~ +9999, H-SC(High limit) : -999 ~ +9999
 But, there must be offset "1" between L-SC and H-SC.

■ Application of connections

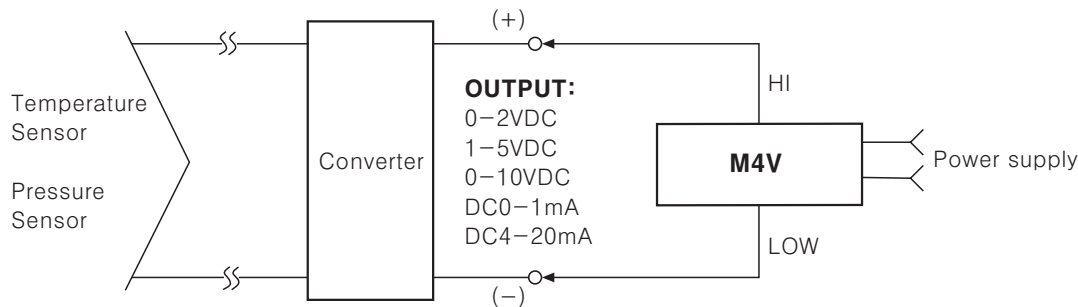

■ Proper usage

- Please read this catalog before purchase Panel meter.
- Ambient condition
 - Please use this product under $-10\sim 50^{\circ}\text{C}$ of ambient operating temperature and less than 35~85%RH of humidity. Moreover, use this item near normal temperature 20°C , the most important condition, which manages the accuracy.
 - Please avoid the condition of dew status by rapidly changing temperature.
 - Please avoid too much vibration or shock.
 - Please avoid the place where there are dreg, dust, and chemical agent or gas, which is destructive to electrical parts.
 - Do not use this item where the voltage or noise is over the proper specification. It may cause malfunction.

● Storage

When you keep it, please avoid a direct ray of light and keep it under $-20\sim 60^{\circ}\text{C}$ of ambient operating temperature and less than 35~85%RH of humidity. Wrap and keep it as initial state.

● Input Line

Shield wire must be used when the measuring input line is getting longer or there are too much noise.

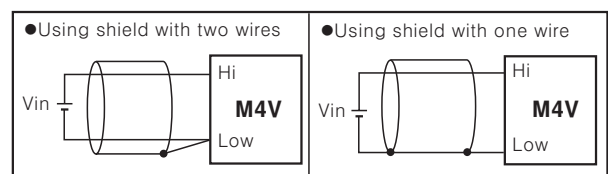

- (A) Counter
- (B) Timer
- (C) Temp. controller
- (D) Power controller
- (E) Panel meter
- (F) Tacho/Speed/Pulse meter
- (G) Display unit
- (H) Sensor controller
- (I) Switching power supply
- (J) Proximity sensor
- (K) Photo electric sensor
- (L) Pressure sensor
- (M) Rotary encoder
- (N) Stepping motor & Driver & Controller
- (O) Graphic panel
- (P) Production stoppage models & replacement