

T3HA/T3HS/T4MA/T4LA

ALARM, SUB output type

■ Features

- Alarm, SUB output type
- High accuracy measurement : ± 0.5
- Various size



⚠ Please read "Caution for your safety" in operation manual before using.

■ Ordering information

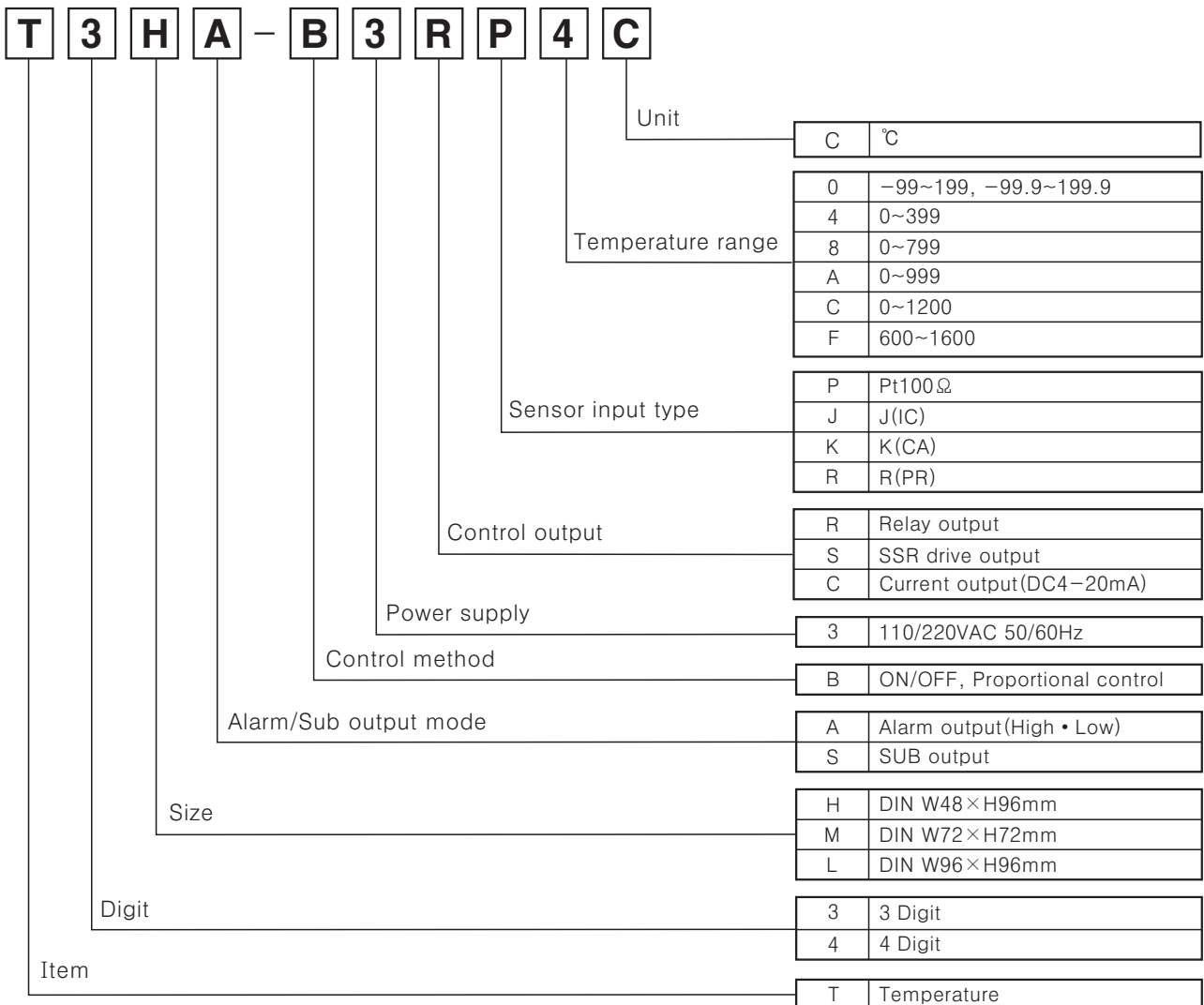

※ See C-58 about sensor temperature range for selection.

T3HA/T3HS/T4MA/T4LA

Connections

※RTD(Resistance Temperature Detector) : Pt 100Ω(3-wire type) ※Thermocouple : K, J, R

●T3HA, T3HS

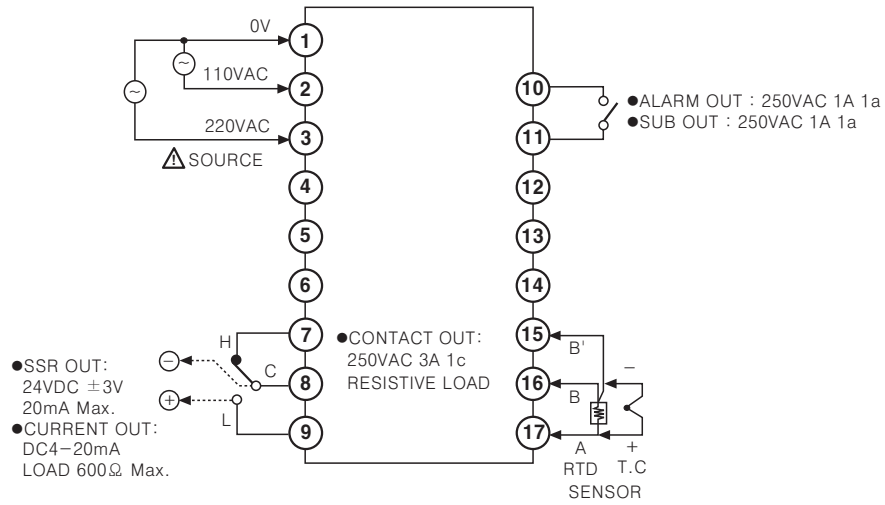

●T4MA

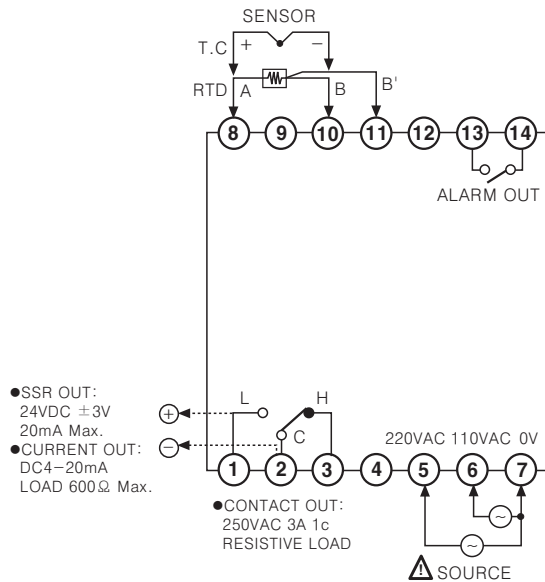

●T4LA

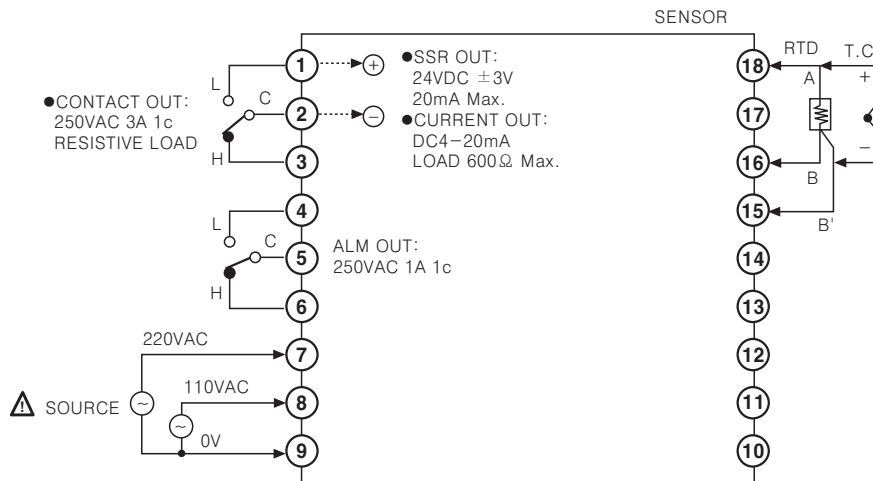

Alarm Output Type

■ Dimensions

● T3HA, T3HS

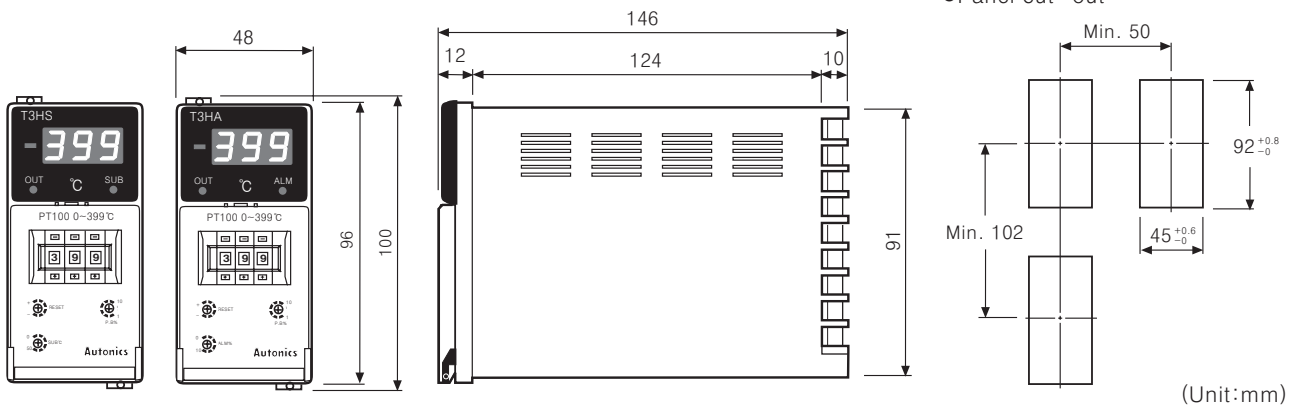

● T4MA

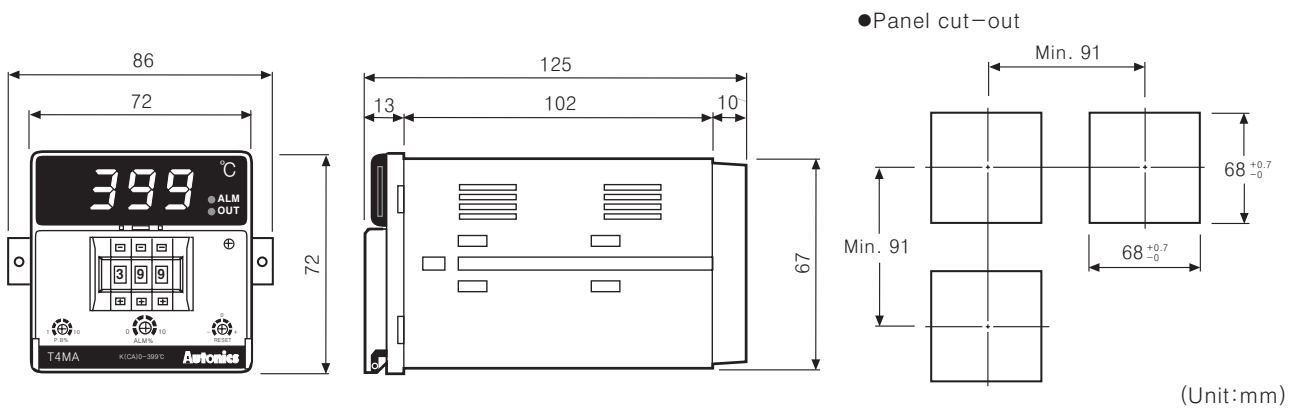

● T4LA

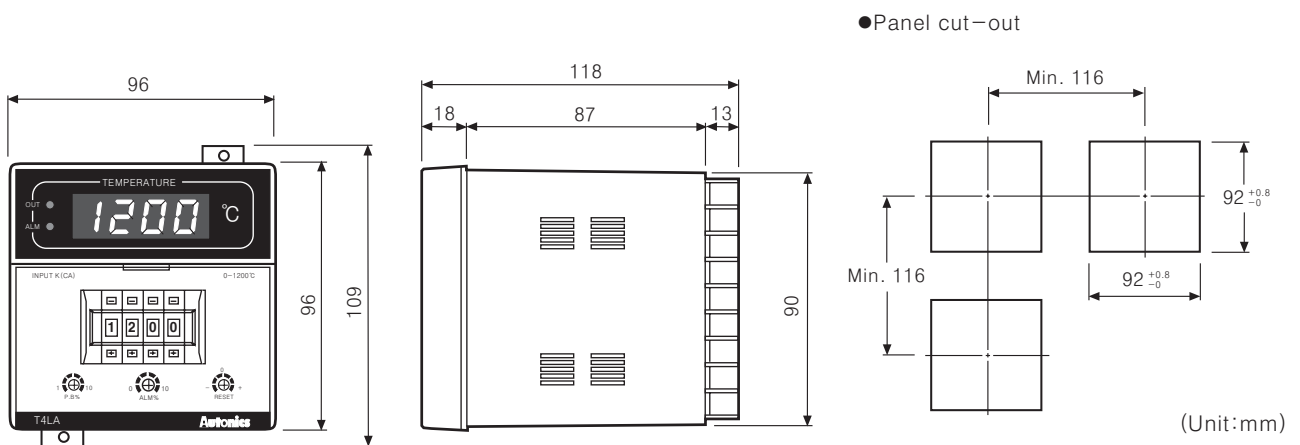

(A)
Counter

(B)
Timer

(C)
Temp. controller

(D)
Power controller

(E)
Panel meter

(F)
Tacho/ Speed/ Pulse meter

(G)
Display unit

(H)
Sensor controller

(I)
Switching power supply

(J)
Proximity sensor

(K)
Photo electric sensor

(L)
Pressure sensor

(M)
Rotary encoder

(N)
Stepping motor & Driver & Controller

(O)
Graphic panel

(P)
Field network device

(Q)
Production stoppage models & replacement

T3HA/T3HS/T4MA/T4LA

Proper usage

Using front adjuster

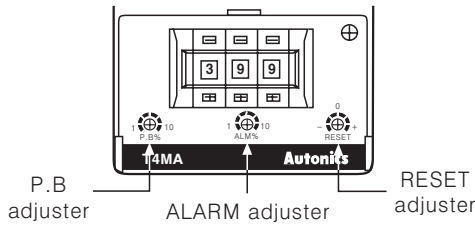

P.B adjuster

In case of ON/OFF control, set variable $F \cdot S$ 0.2~3% of hysteresis, and in case of proportional control, set variable $F \cdot S$ 1~10% of hysteresis.

ALARM adjuster

It adjusts alarm range ($F \cdot S$ 1~10%) and having 1:1 range for upper and lower limited range by set value.

Ex) In case the full scale of temperature controller is 400°C , if setting alarm range is maximum, the value is $400^{\circ}\text{C} \times 0.1 = 40^{\circ}\text{C}$. And the alarm range is high-limit 40°C and lower-limit 40°C .

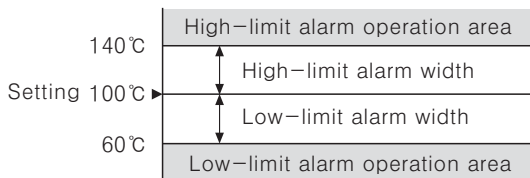

(Note) Full scale (F.S) of the alarm is from 0° up to max. temperature.

Ex) In case of using temperature is from $-99 \sim 199^{\circ}\text{C}$, Full scale is 299°C .

RESET adjuster

It corrects offset can be occurred by proportional control and has $F \cdot S \pm 3\%$ of adjustable range. Do not operate the adjuster when it is used as ON/OFF control.

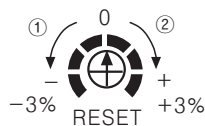

① Turn left when offset value is higher than set value. (Direction ①)

② Turn right when offset value is lower than set value. (Direction ②)

Case detachment

T4MA



T3HA(S)/T4LA

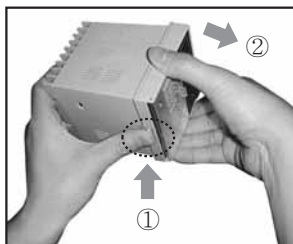

Pressing the front guide of Lock toward ① and Pull squeeze and pull toward ②, it is detached.

Open the front guide, turn it toward ① and pull toward ②, it is detached.

How to select ON/OFF or proportional by plug pin

Factory specification is proportional control. When using ON/OFF control, transfer the switch of control method from P to F after detaching the case from its body. When control output is current output, P control is fixed, there is no switch Pin of control method.



Normal/Reverse operation

Reverse operation executes to output ON when processing value is lower than setting value, and it is used for heating. Normal operation is executed conversely and used for cooling. (This item runs as a reverse operation)

SUB function (T3HS)

SUB output is for alarm used as injector, etc. If the temperature of controlled material reaches to SUB setting value, the SUB output runs and keeps ON continuously.

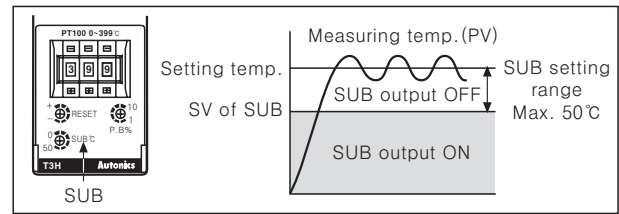

※ SUB function is included only in T3H series.
 ※ SUB range can be set up to 50°C lower than setting value.

Application of temperature controller and load connection

Relay output

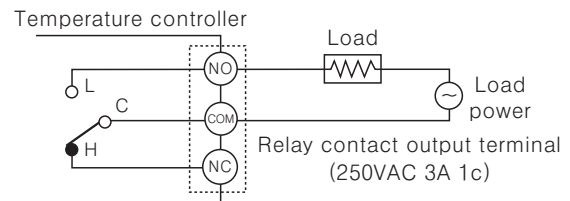

SSR output

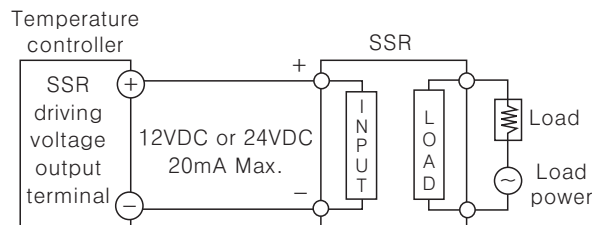

※ When using voltage (for driving SSR) in the other purposes, do not over the range of rated current.

Current output

