

DIN W48 × H48mm, Universal voltage Multi-function Timer

■ Features

- Realization of wide range of power supply
: 24–240VAC 50/60Hz / 24–240VDC, 12VDC (Option)
- Various output operation (6 kinds modes)
- Multi time range (16 kinds of time range)
- Wide control time (0.05sec ~ 100hour)
- Easy setting of time, time range, output operation mode
- Easy to check output status by LED display



⚠ Please read "Caution for your safety" in operation manual before using.



■ Ordering information

AT 8 N

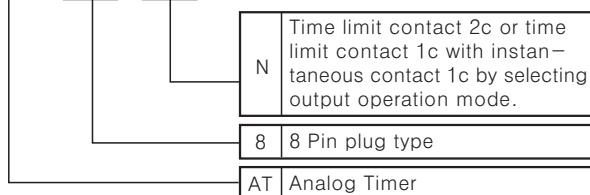

*Socket required : PG-08, PS-08

AT 11 DN

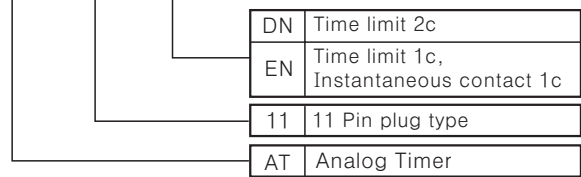

*Socket required : PG-11, PS-11

■ Specifications

Model	AT8N	AT11DN	AT11EN	
Function	MULTI TIMER			
Control time setting range	0.05sec~100hour			
Power supply	24–240VAC 50/60Hz / 24–240VDC, 12VDC (Option)			
Allowable voltage range	90 ~ 110% of rated voltage			
Power consumption	Approx. 3.3VA (24–240VDC 60Hz), Approx. 1.5W (24–240VDC), Approx. 0.5W (12VDC)			
Reset time	Max. 100ms			
Min. input signal width	START input	—	Min. 50ms	
	INHIBIT input			
	RESET input			
Input	START input	—	No-voltage input ⇄ Short-circuit impedance : Max. 1kΩ Residual voltage : Max. 0.5V Open-circuit impedance : Min. 100kΩ	
	INHIBIT input			
	RESET input			
Timing operation	Power ON Start type	Signal ON Start type		
Control output	Contact type	Time limit contact DPDT (2c), Time limit contact DPDT (1c) + Instantaneous contact DPDT (1c) by selecting output operation mode	Time limit DPDT (2c)	Time limit SPDT (1c), Instantaneous contact SPDT (1c)
	Contact capacity	250VAC 3A resistive load		
Relay life cycle	Mechanical	Min. 10,000,000 operations		
	Electrical	Min. 100,000 operations (Rated contact capacity)		
Repeat error	Max. ±0.3%			
SET error	Max. ±5% ±0.05sec			
Voltage error	Max. ±0.5%			
Temperature error	Max. ±2%			
Insulation resistance	Min. 100MΩ (at 500VDC mega)			
Dielectric strength	2000VAC 50/60Hz for 1 minute			
Noise strength	±2kV the square wave noise (pulse width:1μs) by the noise simulator			
Vibration	Mechanical	0.75mm amplitude at frequency of 10 ~ 55Hz in each of X, Y, Z directions for 1 hour		
	Malfunction	0.5mm amplitude at frequency of 10 ~ 55Hz in each of X, Y, Z directions for 10 minutes		
Shock	Mechanical	300m/s ² (Approx. 30G) in X, Y, Z directions 3 times		
	Malfunction	100m/s ² (Approx. 10G) in X, Y, Z directions 3 times		
Ambient temperature	-10 ~ +55°C (at non-freezing status)			
Storage temperature	-25 ~ +65°C (at non-freezing status)			
Ambient humidity	35 ~ 85%RH			
Approval	CE cULUS		cULUS	
Unit weight	Approx. 100g			

(A) Counter

(B) Timer

(C) Temp. controller

(D) Power controller

(E) Panel meter

(F) Tacho/Speed/Pulse meter

(G) Display unit

(H) Sensor controller

(I) Switching power supply

(J) Proximity sensor

(K) Photo electric sensor

(L) Pressure sensor

(M) Rotary encoder

(N) Stepping motor & Driver & Controller

(O) Graphic panel

(P) Production stoppage models & replacement

ATN Series

Connections

AT8N

• [A], [F] mode

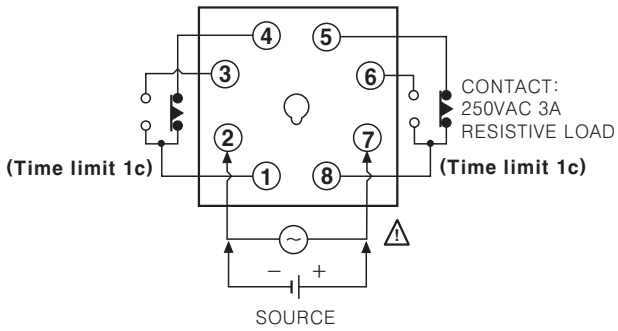

• [A1], [B], [F1], [I] mode

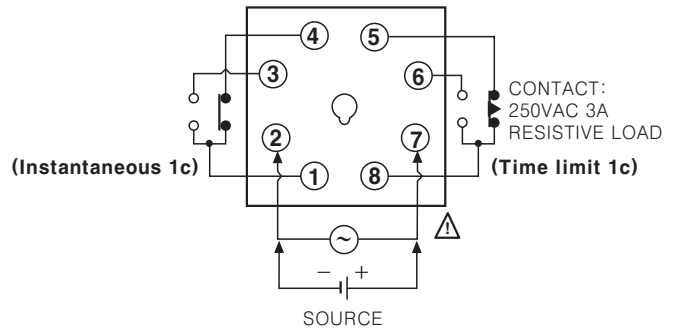

AT11DN

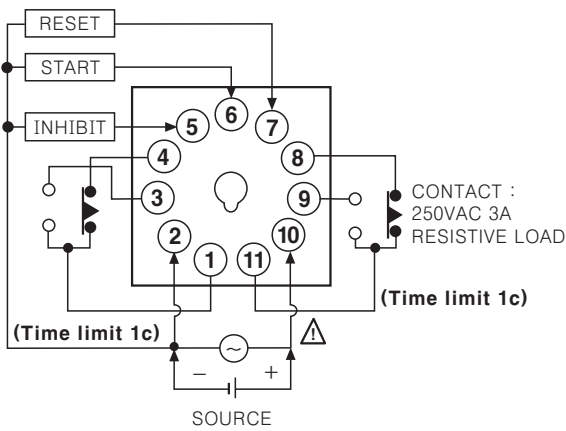

AT11EN

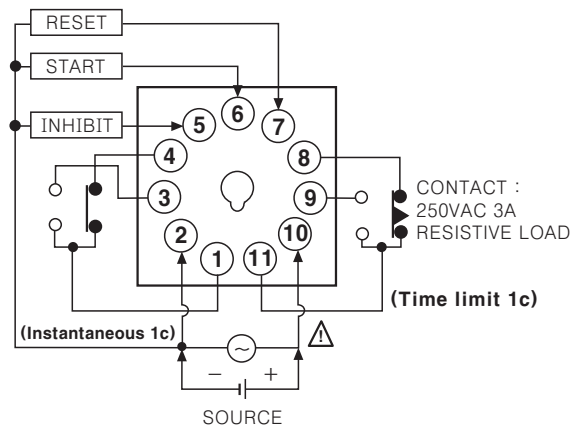

Dimensions

• Bracket

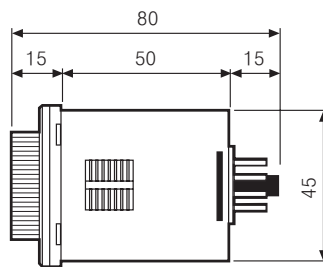
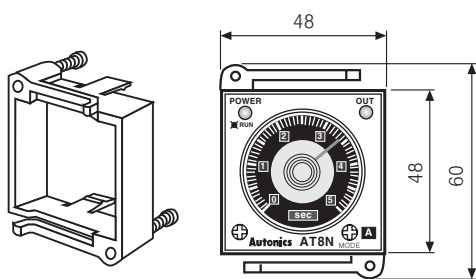

• Panel cut-out

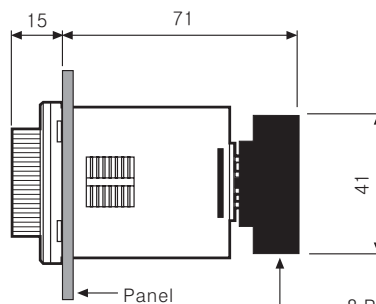
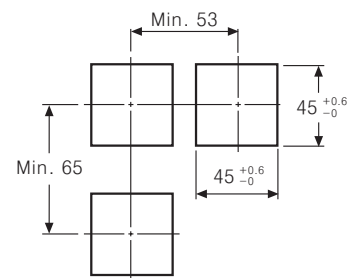

8 Pin socket : PG-08 (Sold separately)
11 Pin socket : PG-11 (Sold separately)

(Unit:mm)

■ Front panel identification

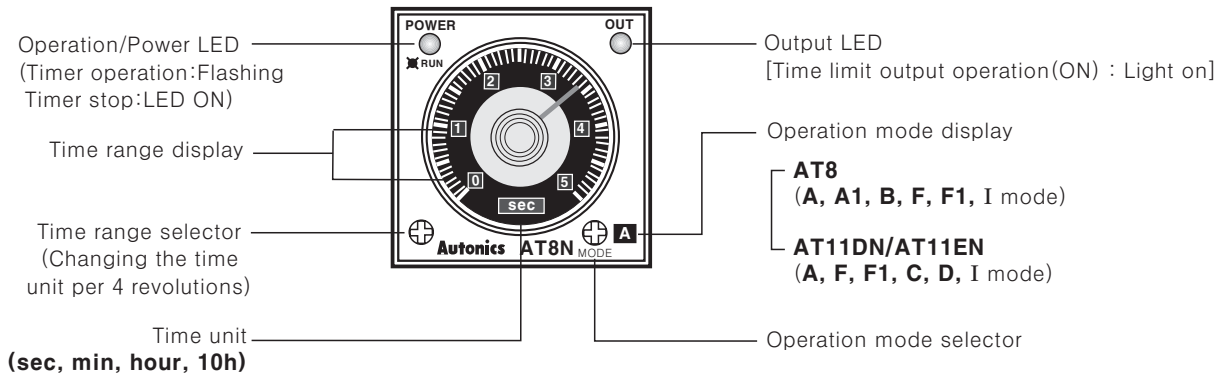

※Please rotate the time range switch and operation mode switch to CW (Clockwise) direction.

■ Time specifications

Time range	Time unit	Time setting range
0.5	sec	0.05~0.5
1.0		0.1~1.0
5		0.5~5
10		1~10
0.5	min	0.05~0.5
1.0		0.1~1.0
5		0.5~5
10		1~10
0.5	hour	0.05~0.5
1.0		0.1~1.0
5		0.5~5
10		1~10
0.5	10h	0.05~0.5
1.0		0.1~1.0
5		0.5~5
10		1~10

■ Output operation mode of each model

●AT8N

Display	Output operation mode
A	POWER ON DELAY
A1	POWER ON DELAY 1
B	POWER ON DELAY 2
F	FLICKER (OFF START)
F1	FLICKER 1 (ON START)
I	INTERVAL

●AT11DN/AT11EN

Display	Output operation mode
A	SIGNAL ON DELAY
F	FLICKER (OFF START)
F1	FLICKER 1 (ON START)
C	SIGNAL OFF DELAY
D	SIGNAL ON/OFF DELAY
I	INTERVAL

(A)
Counter

(B)
Timer

(C)
Temp.
controller

(D)
Power
controller

(E)
Panel
meter

(F)
Tacho/
Speed/
Pulse
meter

(G)
Display
unit

(H)
Sensor
controller

(I)
Switching
power
supply

(J)
Proximity
sensor

(K)
Photo
electric
sensor

(L)
Pressure
sensor

(M)
Rotary
encoder

(N)
Stepping
motor &
Driver &
Controller

(O)
Graphic
panel

(P)
Production
stoppage
models &
replacement

ATN Series

Output operation mode(AT8N)

t:Setting time, $t > t-a$, Rt:Reset time(Max. 100ms)

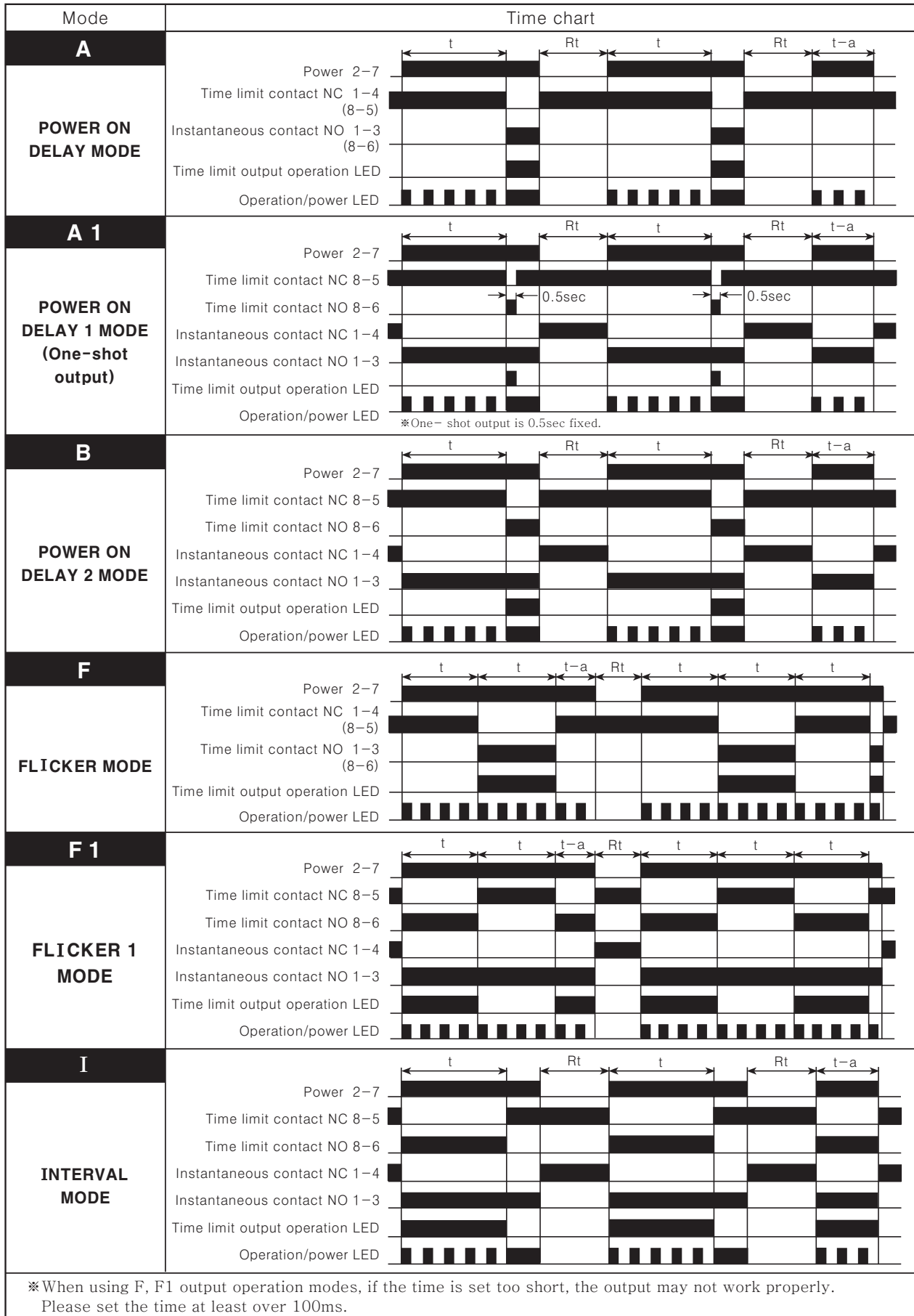

Output operation mode(AT11DN/AT11EN)

$$t=t_1+t_2, t>t-a$$

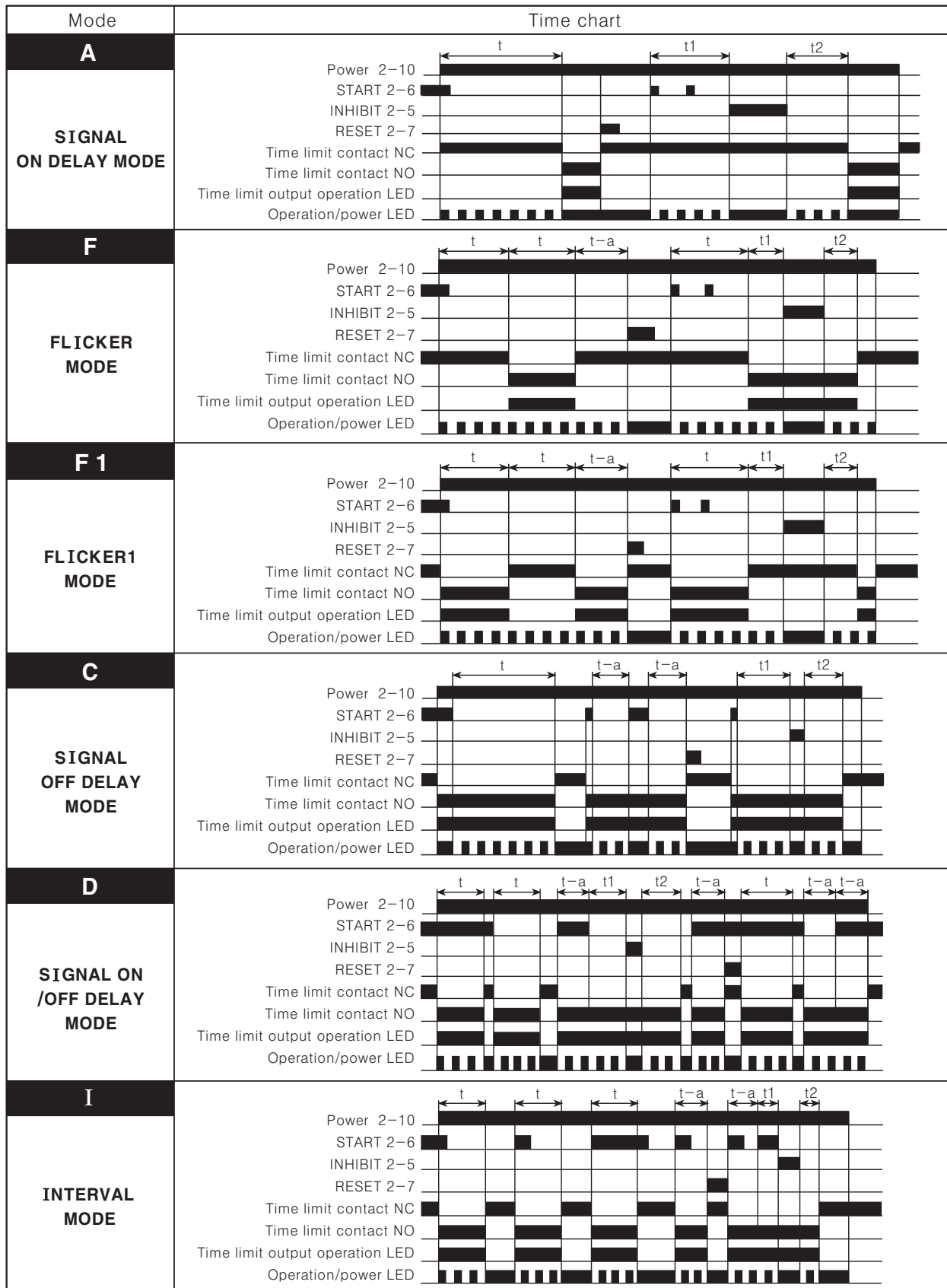

- Note) 1. If power is removed or the RESET terminal is short-circuited, the timer will be reset.
 2. If the INHIBIT terminal is short-circuited during a timing cycle, the time will stop.
 3. When using F, F1 output operation modes, if the time is set too short, the output may not work properly.
 Please set the time at least over 100ms.

- (A) Counter
- (B) Timer
- (C) Temp. controller
- (D) Power controller
- (E) Panel meter
- (F) Tacho/ Speed/ Pulse meter
- (G) Display unit
- (H) Sensor controller
- (I) Switching power supply
- (J) Proximity sensor
- (K) Photo electric sensor
- (L) Pressure sensor
- (M) Rotary encoder
- (N) Stepping motor & Driver & Controller
- (O) Graphic panel
- (P) Production stoppage models & replacement

ATN Series

■ Proper usage

◎ Repeat function (Flicker)

- It enables to use one ATN Timer for 3 Sub Relays and 2 Timers (Flicker function).
Simple to use Flicker function with only one ATN Timer.
- Switch A : Start, Switch B: Reset.

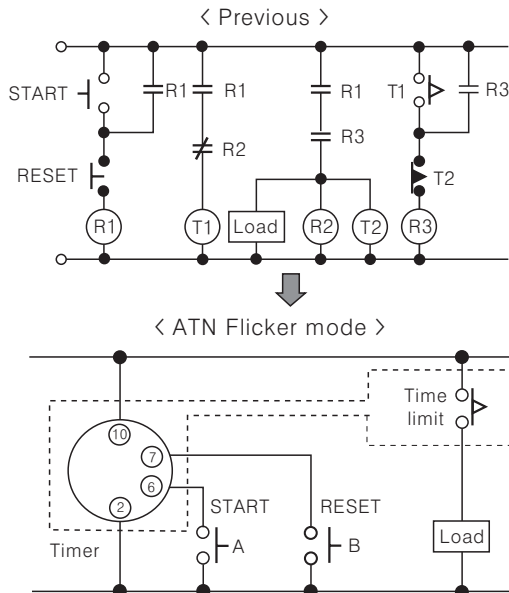

◎ INTERVAL mode

It enables to make Instantaneous ON and Time limit OFF (Remained circuit) with using INTERVAL mode.

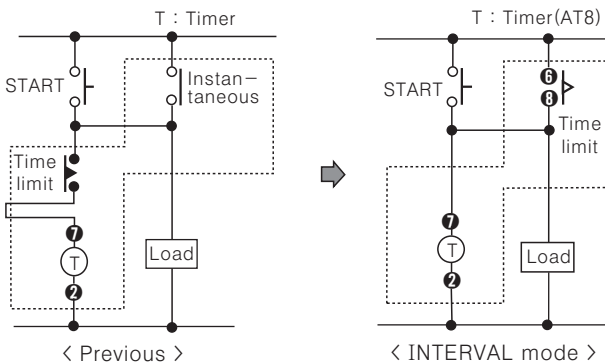

◎ Input signal condition (AT11DN, AT11EN)

1. Relay contact input

Please use gold-plated switches with good contact assurance and short bouncing time for contact input. (Open resistance: Over 100kΩ, Short-circuit resistance: Under 1kΩ)

※ Please use a contact that can function reliably at 5VDC 0.4mA.

2. NPN open collector transistor input

Please use the characteristic of transistor as follow;

V_{ceo} : Min. 25V

I_c : Min. 10mA

I_{cbo} : Max. 0.2μA.

Residual voltage : Max. 0.5V

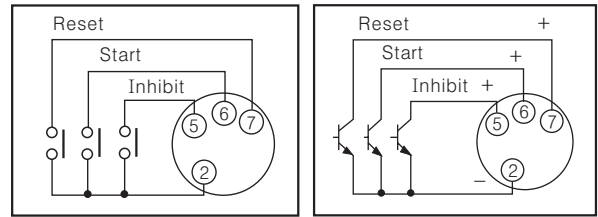

3. NPN universal input

It enables to use voltage output type as input signal source instead of open collector output in Solid-state circuit (Proximity sensor, Photo-electric sensor) which has range of 10-30VDC output voltage.

When H signal change to L, Timer will start.

When transistor (Q) is ON status, please make residual voltage under 0.5V.

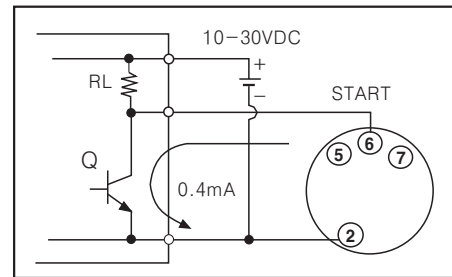

◎ Terminal connection

- 1) Please wire correctly with wiring instructions
- 2) Power connection

Connect the power line without observing polarity for ATN series AC power type, but please be careful of power connection for DC power type.

Power supply	8 Pin Type	11 Pin Type
AC Type	Terminal ② - ⑦	Terminal ② - ⑩
DC Type	Terminal ② ← ⊖ Terminal ⑦ ← ⊕	Terminal ② ← ⊖ Terminal ⑩ ← ⊕

- When turning off the power, be careful of inductive voltage. (If using power line with another high voltage line or energy line near by, it may cause inductive voltage).
 - Power ripple should be under 10% and power supply should be within range of allowable voltage for DC power type.
 - Please supply the power quickly when using a switch or a relay contact. Otherwise, it may cause time error or power reset failure.
- 3) The load of Control output should be under rated load capacity.

◎Setting time, Time range, Operation mode

Do not change time range or operation mode while time operating. When changing it, please power off or apply reset signal.

◎Input connection

1) AT11DN/AT11EN Timer is transformerless type, therefore please check following for connecting relay contact for input signal and transistor.

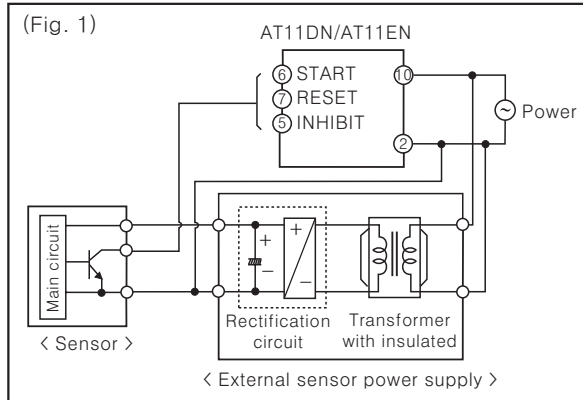

2) When using the terminal ⑩ as a common terminal of input signal as (Fig. 2), it may cause damage to the inner circuit of AT11DN/AT11EN, please use the terminal ② for common terminal as (Fig. 3).

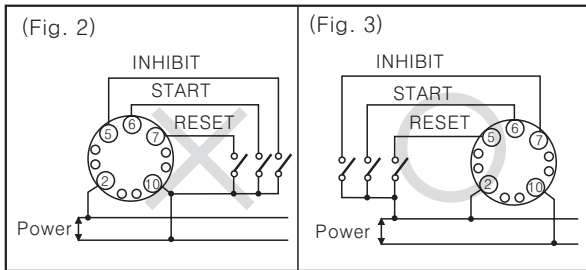

3) When using more than one timer with one contact or transistor input, the short current is flowed when it is connected as (Fig. 4). Please connect the power phase correctly as (Fig. 5) correctly.

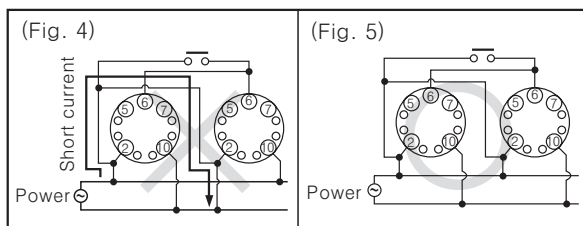

4) INHIBIT, START, RESEST signal applied by short-circuiting input terminal ②-⑤, ②-⑥ or ②-⑦.

It may cause internal circuit damaged by wrong connection.

5) If using power line with another high voltage line or energy line at the same conduit, it may cause inductive voltage. Therefore please use seperated conduit for power line.

6) When input (INHIBIT, START, RESEST) wire is long, plese use shield wire and it should be short.

◎Common

1) If operating the unit in high temperature, it may cause damage to internal components (Electrolytic Condenser etc).

2) Please use it as (Fig. 7) in order not to flow leakage current into timer.

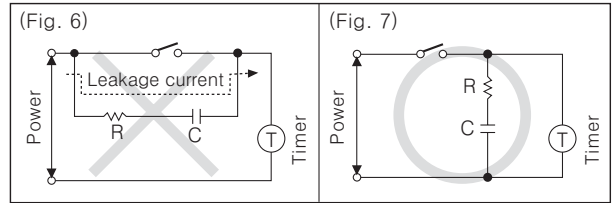

3) Environment

Please avoid the following places:

- Where this product may be damaged by strong impact or vibration.
- Where corrosive gas or flammable gas and water, oil, dust exist.
- Where magnetic and electrical noise occurs.
- Where there are high temperature and humidity beyond rated specification.
- Where there are strong alkalis and acids.
- Where there are direct rays of sun.

(A)	Counter
(B)	Timer
(C)	Temp. controller
(D)	Power controller
(E)	Panel meter
(F)	Tacho/Speed/Pulse meter
(G)	Display unit
(H)	Sensor controller
(I)	Switching power supply
(J)	Proximity sensor
(K)	Photo electric sensor
(L)	Pressure sensor
(M)	Rotary encoder
(N)	Stepping motor & Driver & Controller
(O)	Graphic panel
(P)	Production stoppage models & replacement